

SARAY® | S55

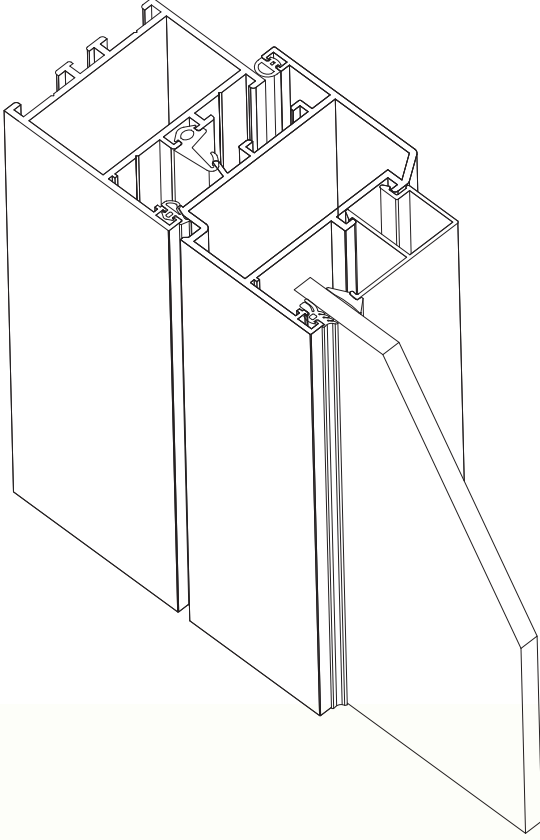









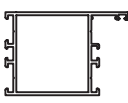

YALITIMSIZ KAPI PENCERE SİSTEMİ

S55
WINDOWS and DOORS
SYSTEM
ALUMINIUM PROFILES

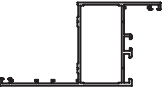
S55
KAPI ve PENCERE SİSTEMİ
ALUMİNYUM PROFİLLER

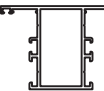
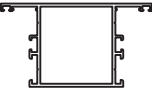
- Profiller
- Profiles



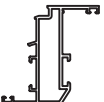
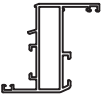



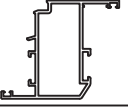
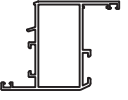
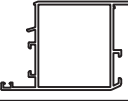
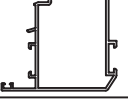
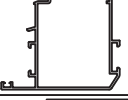
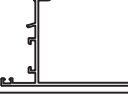

Yalıtımsız Kapi-Pencere Serisi

RESİM PICTURE	PROFİL NO PROFILE NO	PROFİLİN İSMİ PROFILE NAME	AĞIRLIK WEIGHT (kg/m)	Jxx (cm ⁴)	Jyy (cm ⁴)
	5503	27,9 mm Dar Kasa 27,9 mm Frame Profile	1,175	16,60	5,09
	5503/B " 1,5 mm "		1,050	14,58	4,68
	5506	41,7 mm Kasa 44 mm Frame Profile	1,325	21,29	12,36
	5506/B " 1,5 mm "		1,115	18,27	11,00
	5509	62 mm Geniş Kasa 62 mm Frame Profile	1,545	35,89	23,93
	5509/B " 1,5 mm "		1,285	31,14	20,12
	7327 " 1,5 mm "	Z Kasa Z Frame Profile	1,030	18,41	5,55
	8602 " 1,5 mm "	Z Kasa Z Frame Profile	1,210	38,30	11,39
	5501	27,9 mm Dar Orta Kayıt Profili 27,9 mm Mullion Profile	1,275	18,21	8,56
	5501-B " 1,5 mm "		1,090	15,89	7,78
	5504	41,7 mm Orta Kayıt Profili 41,7 mm Mullion Profile	1,425	22,19	18,24
	5504-B " 1,5 mm "		1,195	18,92	16,22
	5507	62 mm Geniş Orta Kayıt Profili 62 mm Mullion Profile	1,645	28,01	41,68
	5510	92 mm Geniş Orta Kayıt Profili 92 mm Mullion Profile	1,970	36,57	99,64
	5512	62 mm Çok Amaçlı Profili 62 mm Special Profile	1,450	23,01	27,46
	5511	92 mm Çok Amaçlı Profili 92 mm Special Profile	1,860	33,69	91,36
	5502	45 mm Dar Kanat Profili 45 mm Sash Profile	1,275	27,78	5,22
	5502-B " 1,5 mm "		1,090	24,07	4,68
	5515	45 mm Düz Dar Kanat Profili 45 mm Flat Sash Profile	1,235	23,10	5,46
	5515/B " 1,5 mm "		1,040	20,03	4,91

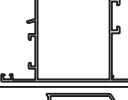
Uyarı: Profil ağırlıklarımız teorik olup; teslim anındaki tartımız geçerlidir.
Warning: the weights of profile is theoretical, weighting at the time of delivery are valid.

- Profiller
- Profiles

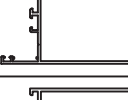
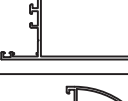
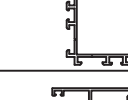











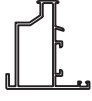





Yalıtımsız Kapı-Pencere Serisi

RESİM PICTURE	PROFİL NO PROFILE NO	PROFİLİN İSMİ PROFILE NAME	AĞIRLIK WEIGHT (kg/m)	Jxx (cm ⁴)	Jyy (cm ⁴)
	5505	59 mm Kanat Profili	1,460	35,91	12,64
	5505/B " 1,5 mm "	59 mm Sash Profile	1,220	31,47	10,81
	5516	59 mm Düz Kanat Profili	1,385	29,84	12,26
	5551	79,3 mm Düz Geniş Kanat Profili	1,610	46,56	24,42
	7355	76 mm Geniş Kanat Profili	1,510	44,96	22,86
	7325 " 1,5 mm "	78,3 mm Geniş Kanat Profili	1,330	43,24	21,04
	5508	94,6 mm Kanat Profili	1,845	37,50	74,51
	5517	94,6 mm Düz Kanat Profili	1,770	31,83	68,89
	7324 " 1,5 mm "	Dışa Açılır Kapı Kanat Profili	1,330	29,06	33,43
	7324/B " 2 mm "	Dışa Açılır Kapı Kanat Profili	1,675	36,57	40,62
	5514	Dışa Açılır Geniş Kapı Kanat Profili	1,845	43,67	66,85
	7326	81 mm Etek Profili	1,350	----	----
	7353	121 mm Etek Profili	1,890	----	----
	5513	151 mm Etek Profili	2,420	----	----
	11271 " 1,5 mm "	90° Dönüş Profili	1,110	----	----
	5518	Çift Kapı Adaptörü	0,915	----	----

Uyarı: Profil ağırlıklarımız teorik olup; teslim anındaki tartımız geçerlidir.
Warning: the weights of profile is theoretical, weighting at the time of delivery are valid.

- Profiller
- Profiles

Yalıtımsız Kapı-Pencere Serisi

RESİM PICTURE	PROFİL NO PROFILE NO	PROFİLİN İSMİ PROFILE NAME	AĞIRLIK WEIGHT (kg/m)	Jxx (cm ⁴)	Jyy (cm ⁴)
	5520	Çarpma Kapı Adaptörü Adapter Profile for Swing Door	0,285	----	----
	5540	Çarpma Kapı Adaptörü Adapter Profile for Swing Do	0,360	----	----
	5529	Dışa Açılır Kapı Adaptörü Adapter Profile for Outside Opening Door	0,900	----	----
	5519	Pivot İçin Adaptörü Pivot Adapter	1,040	----	----
	5521	Kanat Adaptörü Adapter Profile for Door	0,405	----	----
	5522	Kasa Adaptörü Adapter Profile for Frame	0,140	----	----
	877	Tij Profili Pushing Rod Profile	0,130	----	----
	5527	Fugalı T Bini T Profile	0,200	----	----
	5525	39 mm Cam Çıtası 39 mm Glazing Bead	0,310	----	----
	5570	37,5 mm Cam Çıtası 37,5 mm Glazing Bead	0,305	----	----
	310	35 mm Cam Çıtası 35 mm Glazing Bead	0,295	----	----
	342	32 mm Cam Çıtası 32 mm Glazing Bead	0,285	----	----
	5599	29 mm Cam Çıtası 29 mm Glazing Bead	0,275	----	----
	397	26 mm Cam Çıtası 26 mm Glazing Bead	0,265	----	----
	5524	24 mm Cam Çıtası 24 mm Glazing Bead	0,260	----	----
	5576	22,5 mm Cam Çıtası 22,5 mm Glazing Bead	0,260	----	----
	344	19 mm Cam Çıtası 19 mm Glazing Bead	0,245	----	----
	5526	15 mm Cam Çıtası 15 mm Glazing Bead	0,240	----	----
	5536	12 mm Cam Çıtası 12 mm Glazing Bead	0,230	----	----
	5523	Etek Tırnağı ve 4 mm Cam Çıtası 4 mm Glazing Bead	0,185	----	----

Uyarı: Profil ağırlıklarımız teorik olup; teslim anındaki tartımız geçerlidir.
Warning: the weights of profile is theoretical, weighting at the time of delivery are valid.

- Profiller
- Profiles

Yalıtımsız Kapı-Pencere Serisi

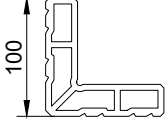
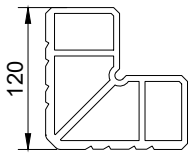
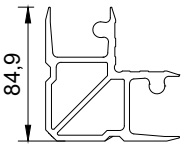
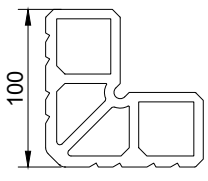
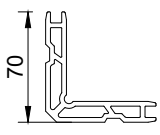
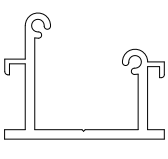
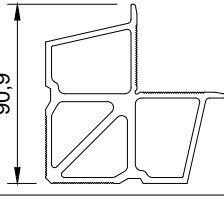
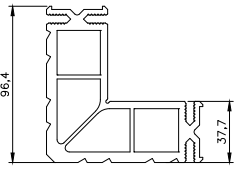
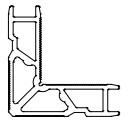
RESİM PICTURE	PROFİL NO PROFILE NO	PROFİLİN İSMİ PROFILE NAME	AĞIRLIK WEIGHT (kg/m)	Jxx (cm ⁴)	Jyy (cm ⁴)
	339	27 mm Köşe Takoğu Corner Joint Profile	6,230	-----	-----
	4036	62,5 mm Köşe Takoğu Corner Joint Profile	9,800	-----	-----
	4574	44,4 mm Köşe Takoğu Corner Joint Profile	4,135	-----	-----
	5539	47,3 mm Köşe Takoğu Corner Joint Profile	8,310	-----	-----
	9084	13,2 mm Köşe Takoğu Corner Joint Profile	2,370	-----	-----
	5550	Dik Bağlantı T Connection Profile	1,060	-----	-----
	9136	46,3 mm Köşe Takoğu Corner Joint Profile	4,030	-----	-----
	341	37,7 mm Köşe Takoğu 37,7 mm Corner Cleat	6,121	-----	-----
	9133	20,3 mm Köşe Takoğu 20,3 mm Corner Cleat	2,715	-----	-----





Uyarı: Profil ağırlıklarımız teorik olup; teslim anındaki tartımız geçerlidir.
Warning: the weights of profile is theoretical, weighting at the time of delivery are valid.

S55
WINDOWS and DOORS
SYSTEM
GASKETS and ACCESSORIES

S55
KAPI ve PENCERE SİSTEMİ
CONTA ve AKSESUARLAR



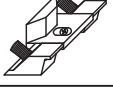

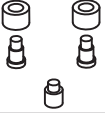
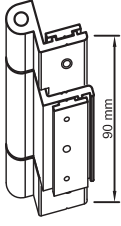
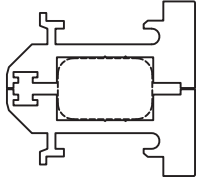
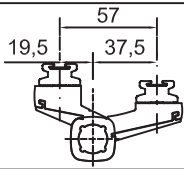
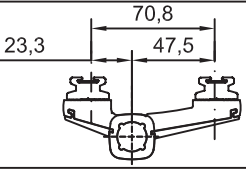
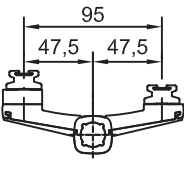

- Aksesuarlar
- Accessories

Yalıtımsız Kapı-Pencere Serisi

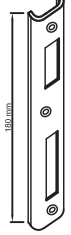
Çizim DRAWING	Aksesuar Kodu CODE	Malzeme MATERIAL	Malzeme Tanımı DESCRIPTION	Koli / Paket PACKAGING
	SC-041	PVC	İçe açılır kanat için kaldırma takoz SLOPED SYNTHETIC BLOCK INSIDE OPENING WINDOW	25 tk/pk
	SC-047	Paslanmaz	2000 Seri Köşe Onbaşı CORNER JOINT	500 ad/pk
	SC-222	Metal	Ayarlı İspanyolet Karşılığı ADJUSTABLE LOCKING DEVICE	50 ad/pk
	SC-260	PVC	Su Tahliye Tapası WATER DRAINAGE CAP	500 ad/pk
	SC-270		Perdeli Su Tahliye Tapası WATER DRAINAGE CAP	
	SC-261	Metal	İspanyolet Pim LOCKING DEVICE PIECES	100 ad/pk
	SC-825	Alüminyum	Pencere Menteşesi "2000 Seri" 304-305 (Beyaz boyalı) WINDOW HINGE -white painted	10 ad/pk
	SC-826		Pencere Menteşesi "2000 Seri" 304-305 (Mat Eloksalli) WINDOW HINGE-opaque anodising,	
	SC-827		Pencere Menteşesi "2000 Seri" 304-305 (P. Eloksalli/ R. Boyalı) WINDOW HINGE -bright anodising, special colors	
	SC-840	Alüminyum	Pivot Menteşe " S55 Seri " 5528 (Beyaz boyalı) PIVOT HINGE -white painted	2 ad/pk
	SC-841		Pivot Menteşe " S55 Seri " 5528 (Özel boyalı) PIVOT HINGE special colors	
	SC-842		Pivot Menteşe " S55 Seri " 5528 (Mat/ Parlak Eloksalli) PIVOT HINGE-opaque/ bright andopaque anodising	
	SFKM-55-071	Alüminyum	Fugalı Kapazlama Menteşe Beyaz Boyalı, Mat /Parlak Eloksalli , Özel Renk REBATED DOOR HINGE white painted,opaque/bright anodising, special colors	10 ad/pk
	SDKM-57-076	Alüminyum	Düz Kapazlama Menteşe Beyaz Boyalı, Mat /Parlak Eloksalli , Özel Renk FLAT DOOR HINGE white painted,opaque/bright anodising, special colors	10 ad/pk
	SFKM-58-077	Alüminyum	Adaptörlü Fugalı Kapazlama Menteşe Beyaz Boyalı, Mat /Parlak Eloksalli , Özel Renk REBATED DOOR HINGE with ADAPTER white painted,opaque/bright anodising, special colors	10 ad/pk

- Aksesuarlar
- Accessories

Yalıtımsız Kapı-Pencere Serisi

Çizim DRAWING	Aksesuar Kodu CODE	Malzeme MATERIAL	Malzeme Tanımı DESCRIPTION	Koli / Paket PACKAGING
	SC-230	Alüminyum	Eksenel Kol (Beyaz Boyalı) AXIAL HANDLE (white painted)	5 AD/PK
	SC-231		Eksenel Kol (Eloksalli) AXIAL HANDLE (anodising)	
	SC-232		Eksenel Kol (Özel Renk) AXIAL HANDLE (speical color)	
	SC-870-D	Alüminyum	4023-D Dilli Kilit Karşılığı (Beyaz Boyalı-White painted) LOCK DEVICE for CYLINDER	İstenilen Miktar
	SC-871-D		4023-D Dilli Kilit Karşılığı (Özel Renkler-Special colors) LOCK DEVICE for CYLINDER	
	SC-872-D		4023-D Dilli Kilit Karşılığı (Mat/Parlak Eloksalli-Bright-Opague Anodising) LOCK DEVICE for CYLINDER	
	SC-870-M	Alüminyum	4023-M Makaralı Kilit Karşılığı (Beyaz Boyalı-White painted) LOCK DEVICE for ROLLER	İstenilen Miktar
	SC-871-M		4023-M Makaralı Kilit Karşılığı (Özel Renkler-Special colors) LOCK DEVICE for ROLLER	
	SC-872-M		4023-M Makaralı Kilit Karşılığı (Mat/Parlak Eloksalli-Bright-Opague Anodising) LOCK DEVICE for ROLLER	
	SC-873-D	Alüminyum	311-D Dilli Kilit Karşılığı (Beyaz Boyalı-White painted) LOCK DEVICE for CYLINDER	İstenilen Miktarda
	SC-874-D		311-D Dilli Kilit Karşılığı (Özel Renkler-Special colors) LOCK DEVICE for CYLINDER	
	SC-875-D		311-D Dilli Kilit Karşılığı (Mat/Parlak Eloksalli-Bright-Opague Anodising) LOCK DEVICE for CYLINDER	
	SC-873-M	Alüminyum	311-M Makaralı Kilit Karşılığı (Beyaz Boyalı-White painted) LOCK DEVICE for ROLLER	İstenilen Miktarda
	SC-874-M		311-M Makaralı Kilit Karşılığı (Özel Renkler-Special colors) LOCK DEVICE for ROLLER	
	SC-875-M		311-M Makaralı Kilit Karşılığı (Mat/Parlak Eloksalli-Bright-Opague Anodising) LOCK DEVICE for ROLLER	
	SC-250	Alüminyum	Gömme Sürgü (1556 Savio) SLIDING BUILT-IN (savio) (Beyaz Boyalı - White painted)	5 AD
	SC-251		Gömme Sürgü (1556 Savio) SLIDING BUILT-IN (savio) (Eloksalli- Anodising)	
	SC-252		Gömme Sürgü (1556 Savio) SLIDING BUILT-IN (savio) (Özel Boyalı-Special colors)	
	PV24	PVC	40X15 PVC Korkasa Atksı INSTULATION U for SUBFRAME	150 M (50 AD, 3 m/ad)

- Aksesuarlar
- Accessories

Yalıtımsız Kapı-Pencere Serisi

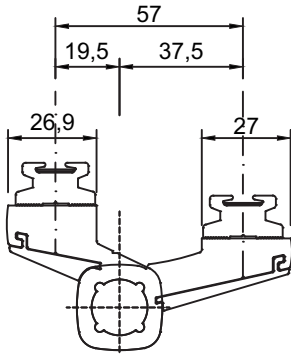
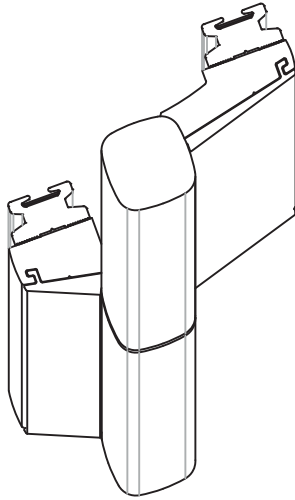

Kod : SFKM-55-071
Fugalı Kapazlama Mentеше
(10 Adet / Paket)

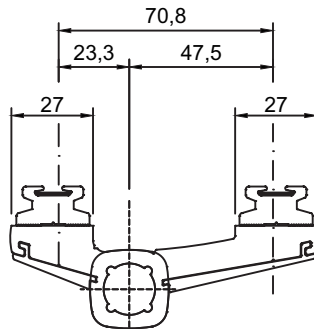
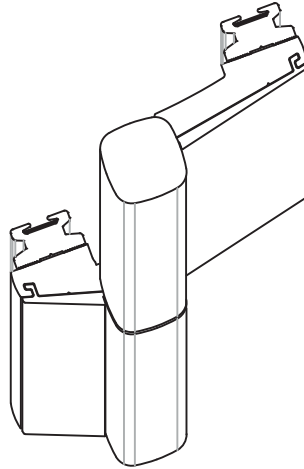

Kod : SDKM-57-076
Düz Kapazlama Mentеше
(10 Adet / Paket)

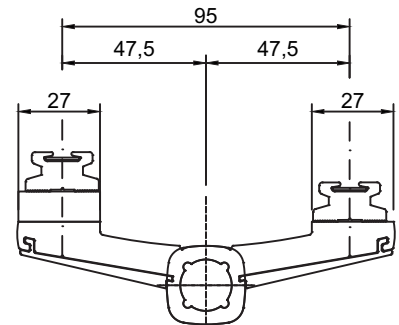
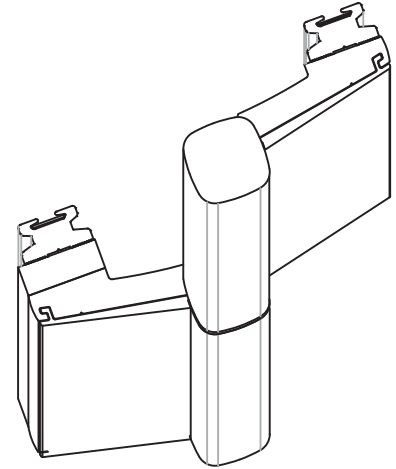

Kod : SFKM-58-077
Fugalı Kapazlama Mentеше
(10 Adet / Paket)

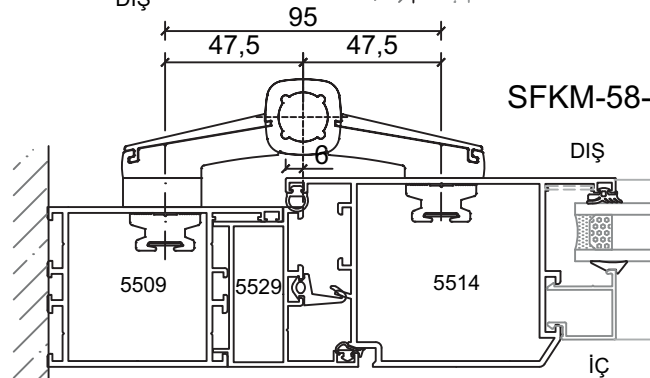
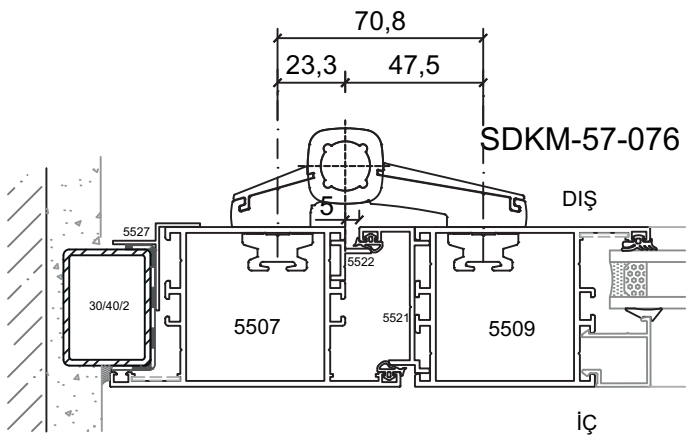
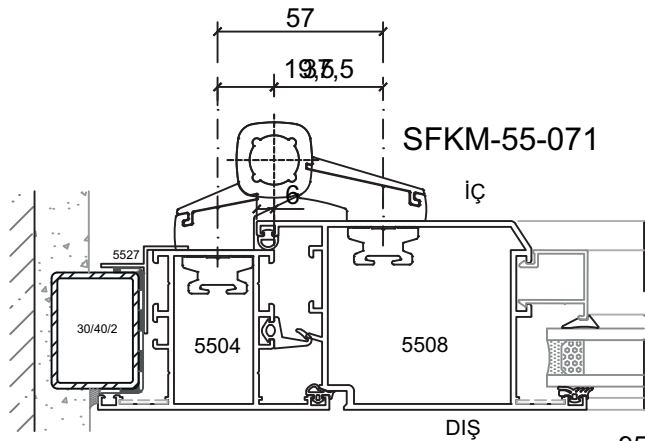

S55
WINDOWS and DOORS
SYSTEM
FULL SCALE SECTIONS

S55
KAPI ve PENCERE SİSTEMİ
1:1 ÖLÇEKLİ PROFİL KESİTLERİ

- Profiller
- Profiles

Yalıtımsız Kapı-Pencere Serisi

Kalın ve İnce Seri Profiller (2 mm-1,5 mm)

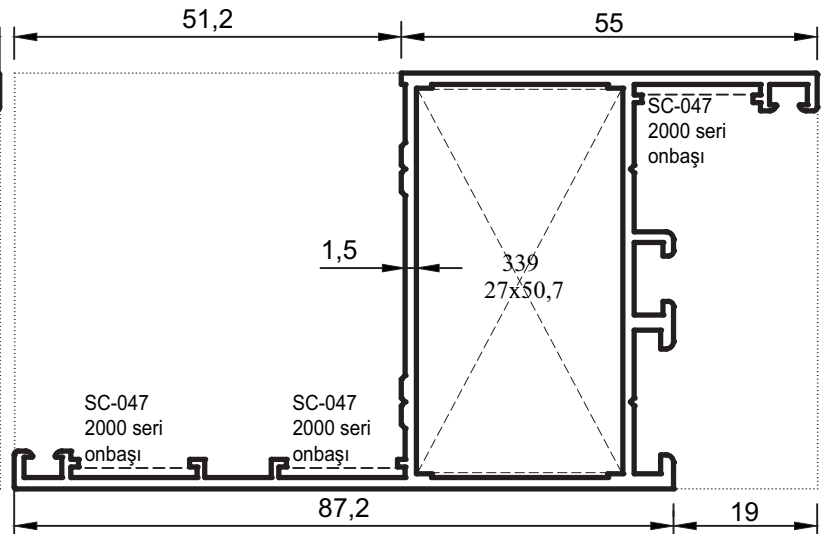
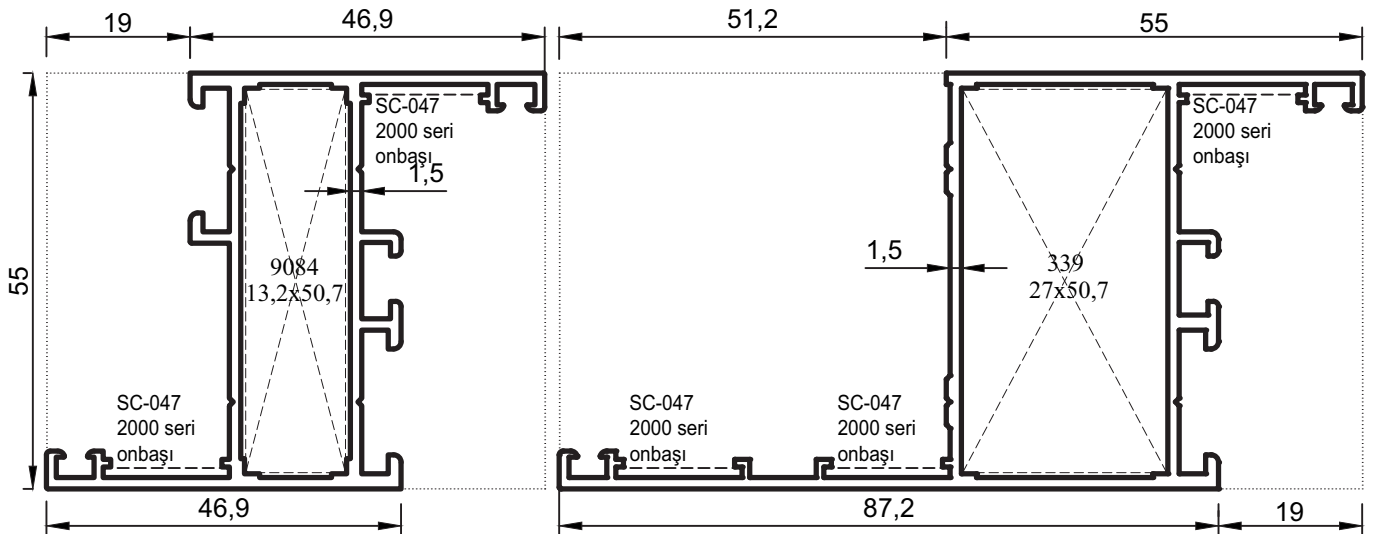
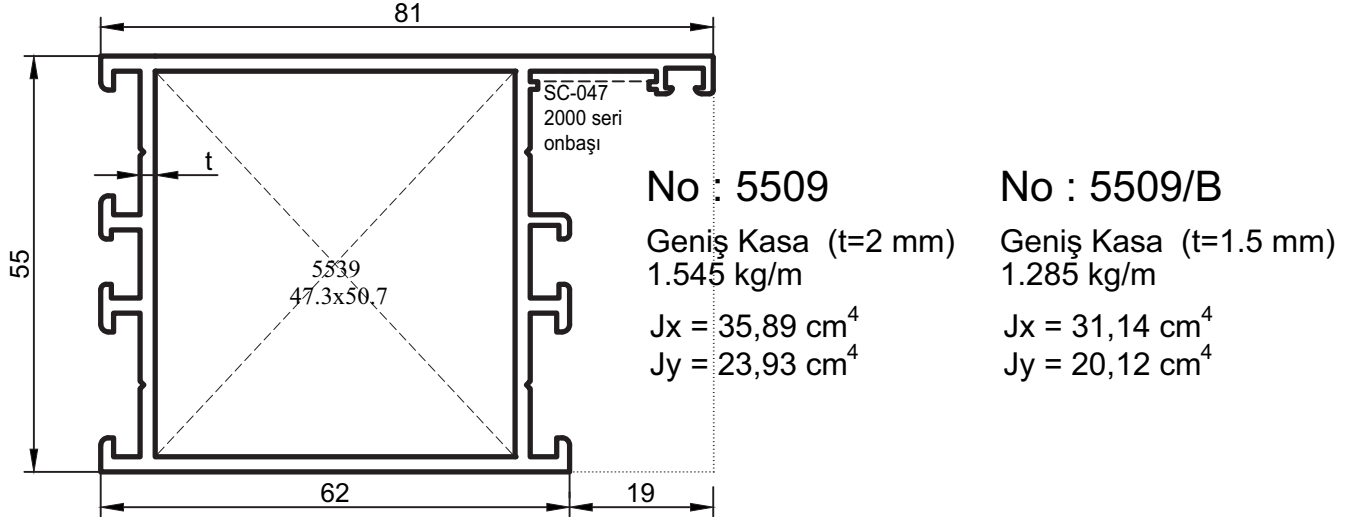
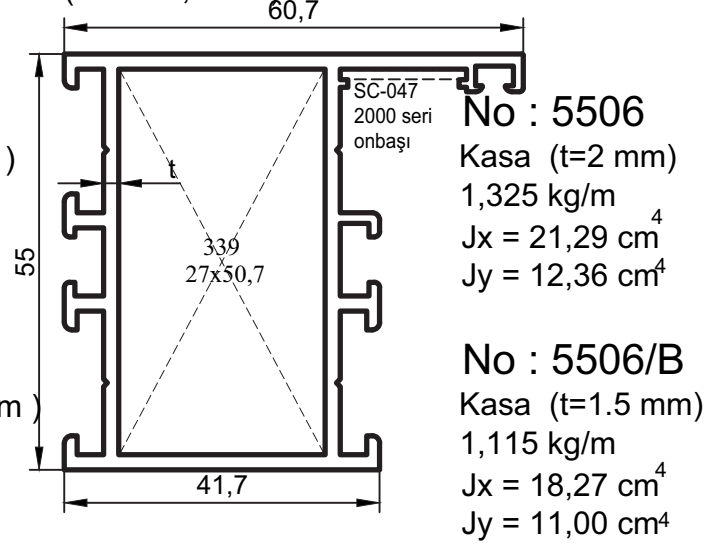
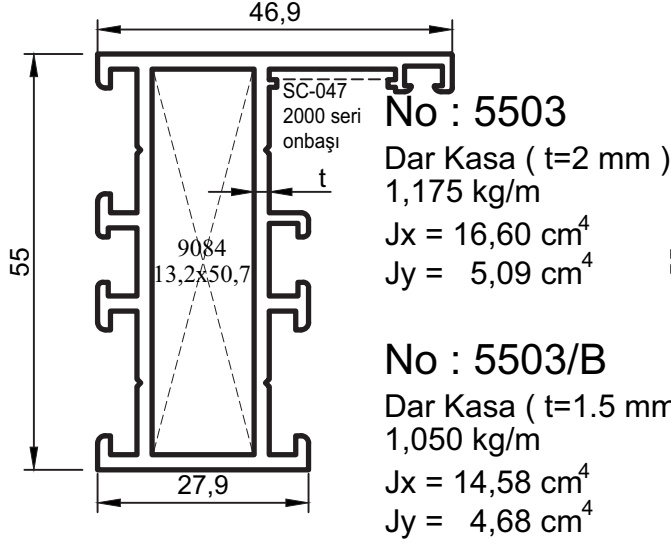

Uyarı: Profil ağırlıklarımız teorik olup; teslim anındaki tartımız geçerlidir. Warning: the weights of profile is theoretical, weighting at the time of delivery are valid.

- Profiller
- Profiles

Yalıtımsız Kapı-Pencere Serisi

Kalın ve İnce Seri Profiller (2 mm-1,5 mm)

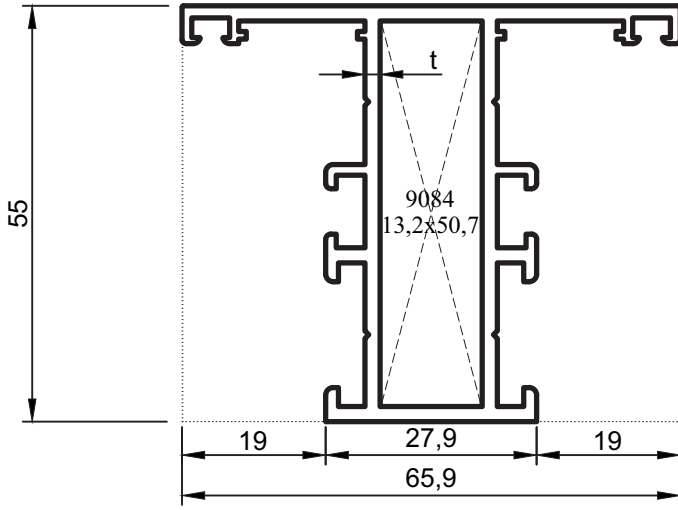

No : 5501

Dar Orta (t= 2 mm)

1,275 kg/m

Jx = 18,21 cm⁴

Jy = 8,56 cm⁴

No : 5501/B

Dar Orta (t=1.5 mm)

1,090 kg/m

Jx = 15,89 cm⁴

Jy = 7,78 cm⁴

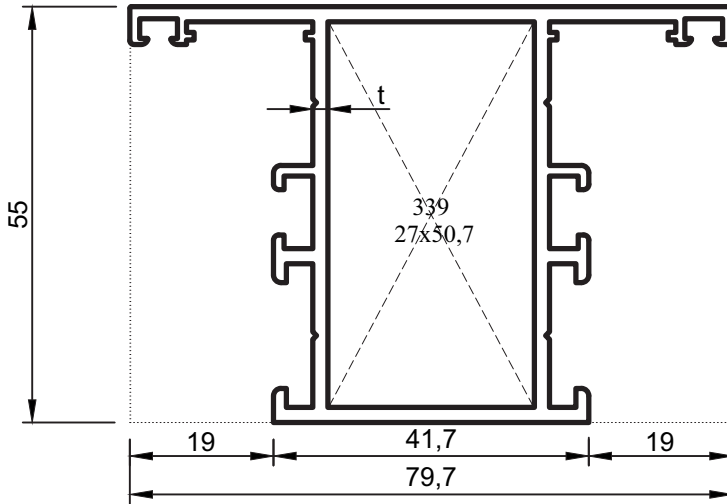

No : 5504

Orta Kayıt (t=2 mm)

1,425 kg/m

Jx = 22,19 cm⁴

Jy = 18,24 cm⁴

No : 5504/B

Orta Kayıt (t=1.5 mm)

1,195 kg/m

Jx = 18,92 cm⁴

Jy = 16,22 cm⁴

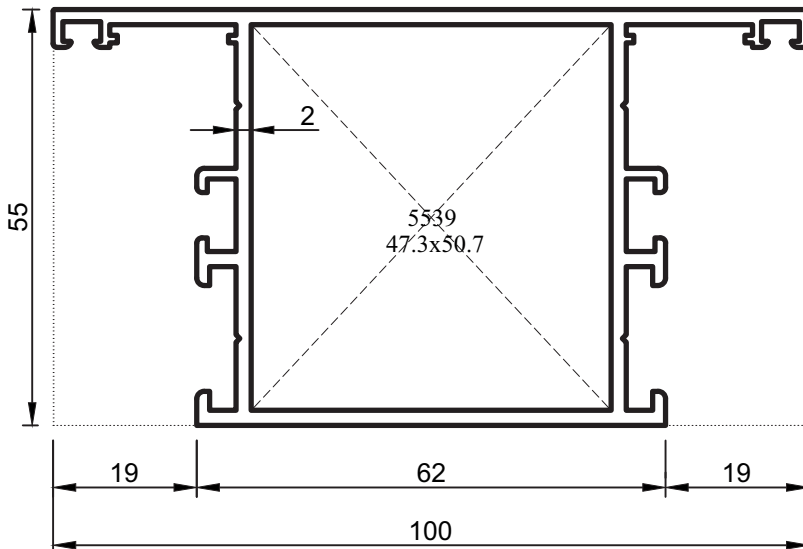

No : 5507

Geniş Orta

1.645 kg/m

Jx = 28,01 cm⁴

Jy = 41,68 cm⁴

- Profiller
- Profiles

Yalıtımsız Kapı-Pencere Serisi

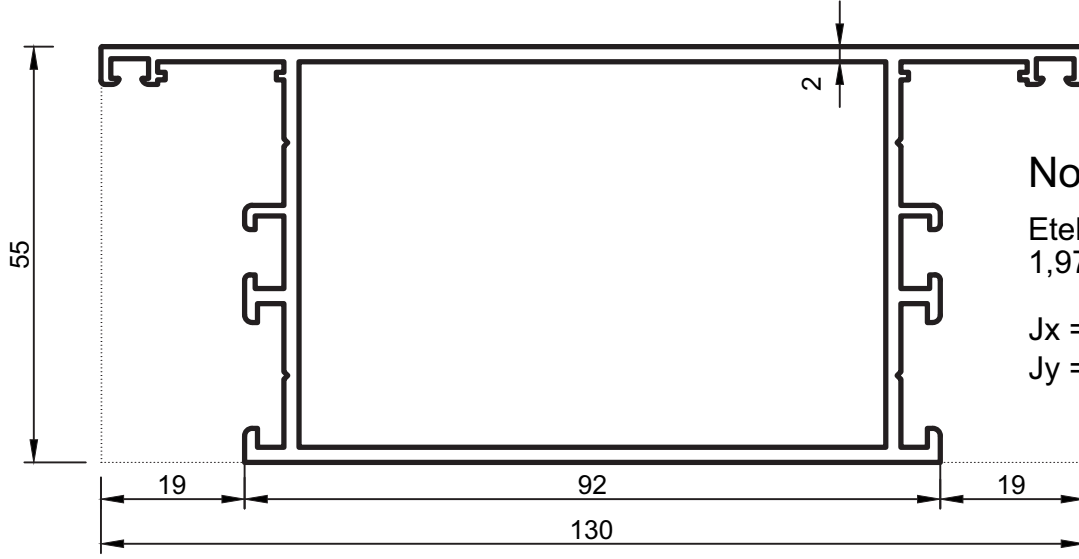

No : 5510

Etek-Geniş Orta
1,970 kg/m

$J_x = 36,57 \text{ cm}^4$
 $J_y = 99,64 \text{ cm}^4$

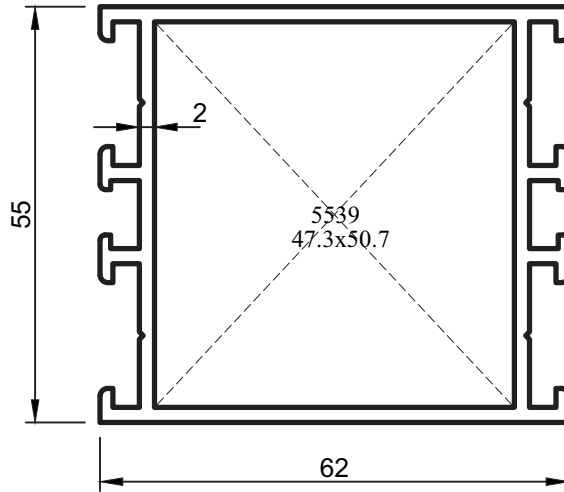

No : 5512

Çok Amaçlı
1,450 kg/m

$J_x = 23,01 \text{ cm}^4$
 $J_y = 27,46 \text{ cm}^4$

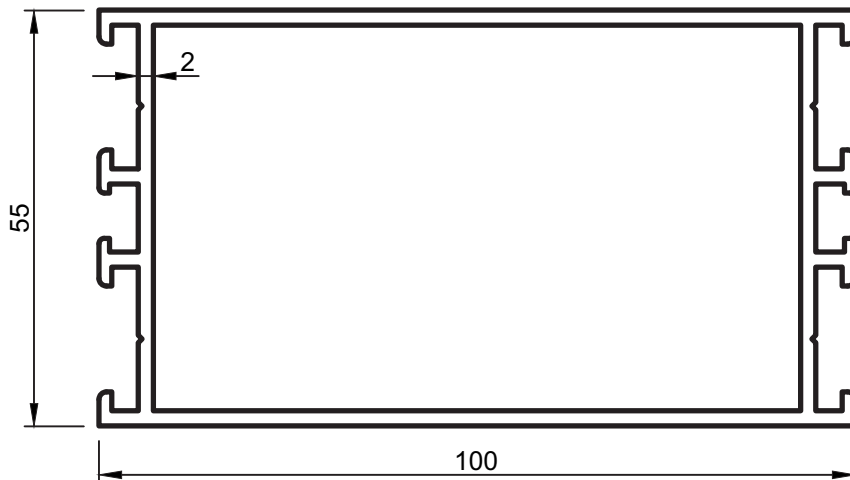

No : 5511

Çok Amaçlı Geniş
1,860 kg/m

$J_x = 33,69 \text{ cm}^4$
 $J_y = 91,36 \text{ cm}^4$

- Profiller
- Profiles

Yalıtımsız Kapı-Pencere Serisi

Kalın ve İnce Seri Profiller (2 mm-1,5 mm)

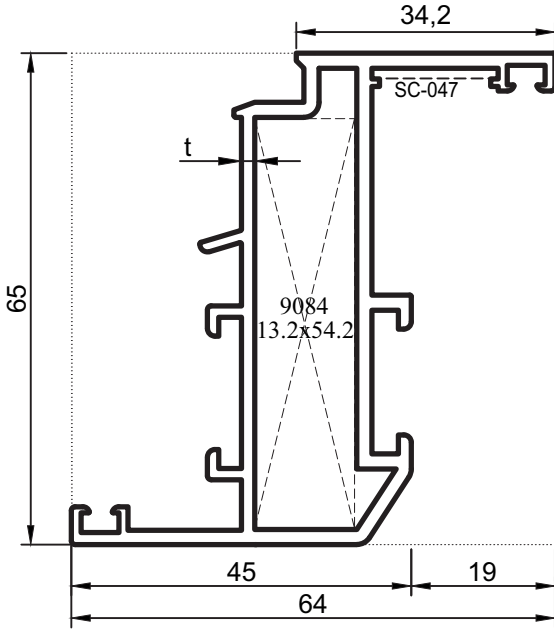

No : 5502

Dar Kanat (t= 2 mm)
1.275 kg/m

$$J_x = 27,78 \text{ cm}^4$$

$$J_y = 5,22 \text{ cm}^4$$

No : 5502/B

Dar Kanat (t=1.5 mm)
1.090 kg/m

$$J_x = 24,07 \text{ cm}^4$$

$$J_y = 4,68 \text{ cm}^4$$

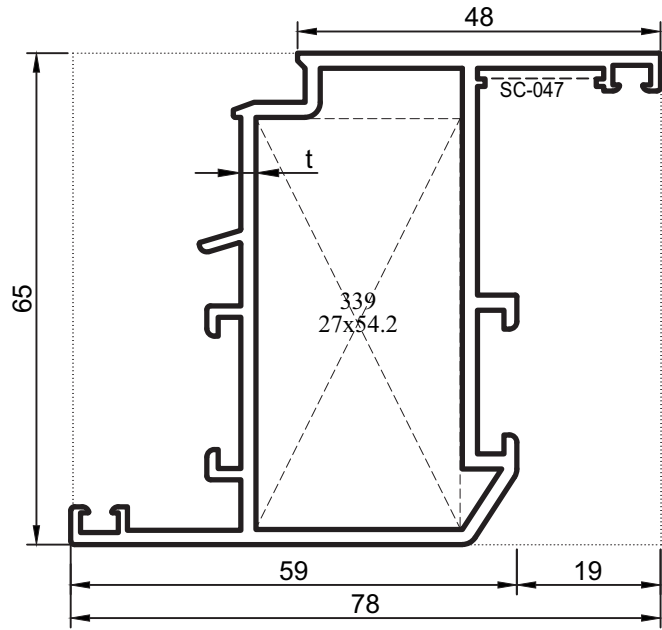

No : 5505

Kanat (t=2 mm)
1.460 kg/m

$$J_x = 35,91 \text{ cm}^4$$

$$J_y = 12,64 \text{ cm}^4$$

No : 5505/B

Kanat (t=1.5 mm)
1.220 kg/m

$$J_x = 31,47 \text{ cm}^4$$

$$J_y = 10,81 \text{ cm}^4$$

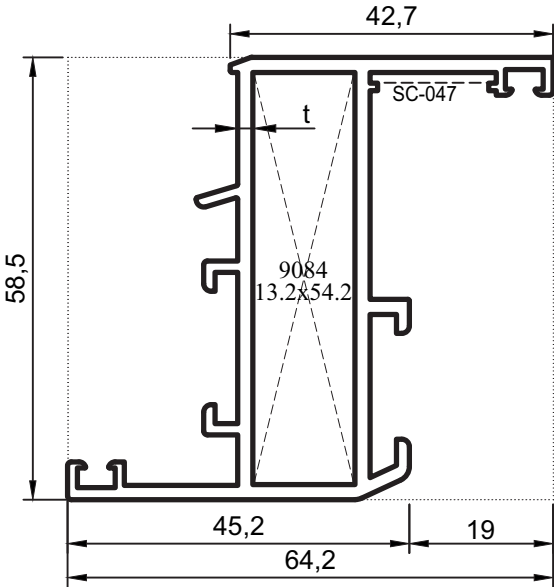

No : 5515

Düz Dar Kanat (t=2 mm)
1.235 kg/m

$$J_x = 23,10 \text{ cm}^4$$

$$J_y = 5,46 \text{ cm}^4$$

No : 5515/B

Düz Dar Kanat (t=1.5 mm)
1.040 kg/m

$$J_x = 20,03 \text{ cm}^4$$

$$J_y = 4,91 \text{ cm}^4$$

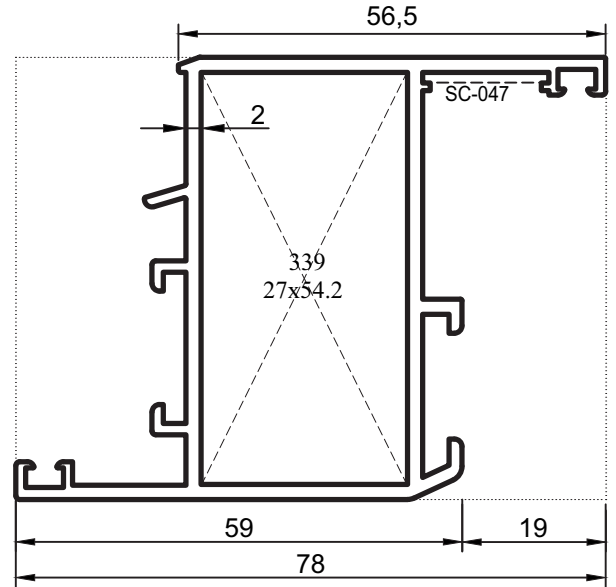

No : 5516

Düz Kanat
1.385 kg/m

$$J_x = 29,84 \text{ cm}^4$$

$$J_y = 12,26 \text{ cm}^4$$

- Profiller
- Profiles

Yalıtımsız Kapı-Pencere Serisi

Kalın ve İnce Seri Profiller (2 mm-1,5 mm)

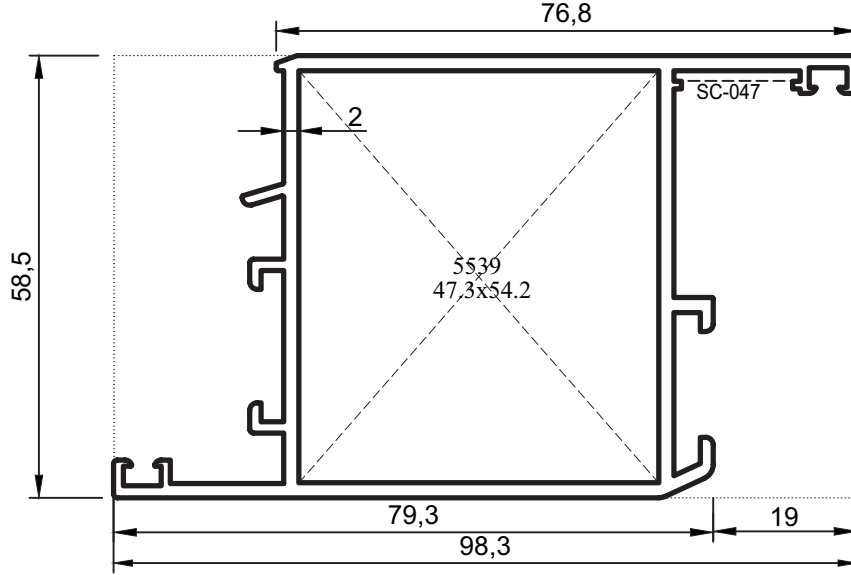

No : 5551

Düz Geniş Kanat
1.610 kg/m

$J_x = 46,56 \text{ cm}^4$
 $J_y = 24,42 \text{ cm}^4$

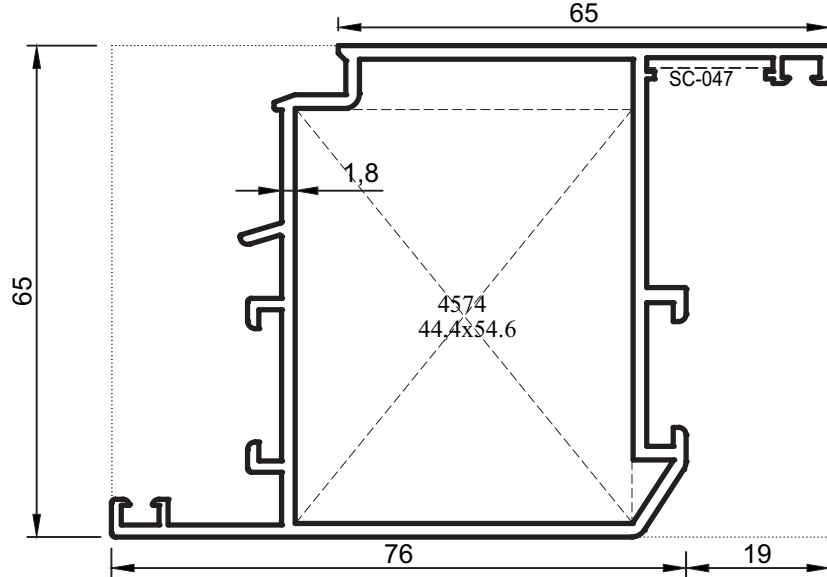

No : 7355

Geniş Kanat
1.510 kg/m

$J_x = 44,96 \text{ cm}^4$
 $J_y = 22,86 \text{ cm}^4$

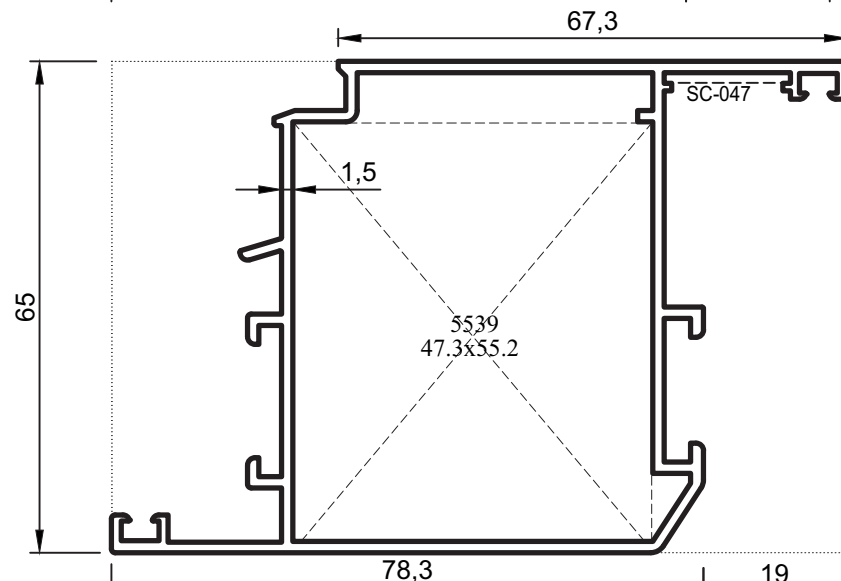

No : 7325

Geniş Kanat
1.330 kg/m

$J_x = 21,04 \text{ cm}^4$
 $J_y = 43,24 \text{ cm}^4$

Uyarı: Profil ağırlıklarımız teorik olup; teslim anındaki tartımız geçerlidir. Warning: the weights of profile is theoretical, weighting at the time of delivery are valid.

- Profiller
- Profiles

Yalıtımsız Kapı-Pencere Serisi

PVC Uyumlu Profiller (1,5 mm)

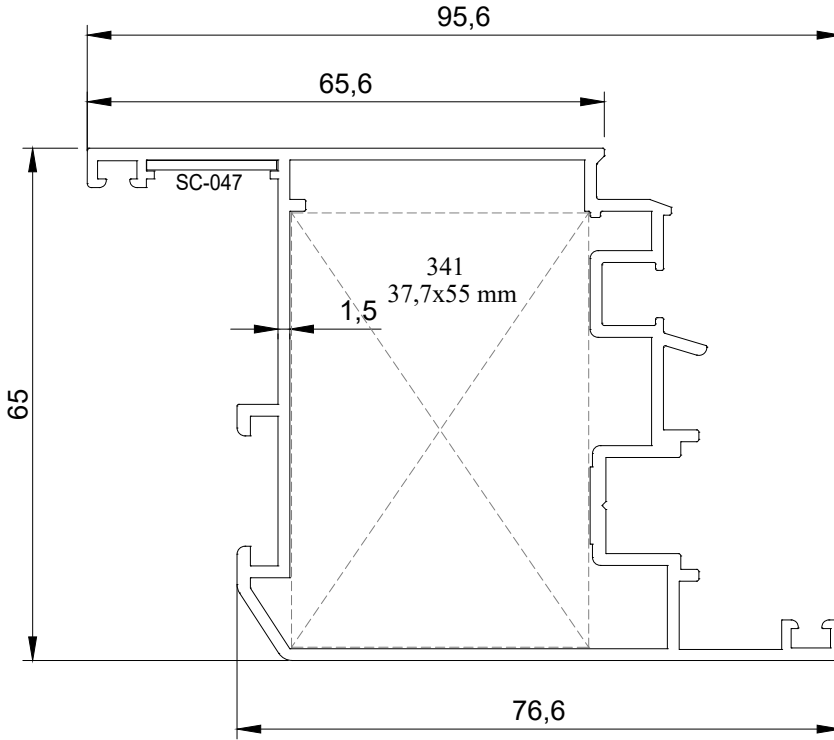

No : 19517

Pvc Kanallı Kanat
1.455 kg/m

Jx = 42,90cm

Jy = 21,34 cm

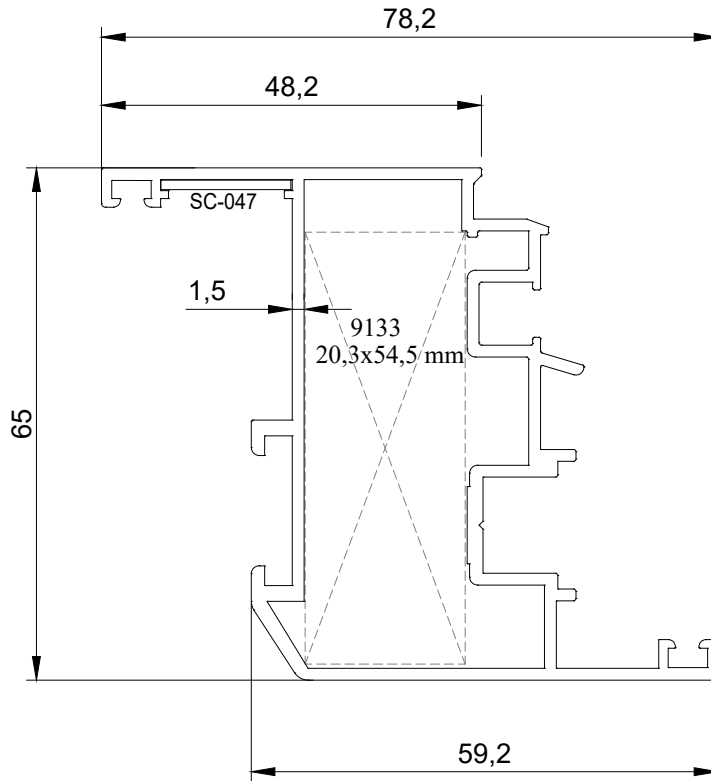

No : 19518

Pvc Kanallı Kanat
1.335 kg/m

Jx = 31,12 cm

Jy = 11,41 cm

- Profiller
- Profiles

Yalıtımsız Kapı-Pencere Serisi

Kalın Seri Profiller (2 mm)

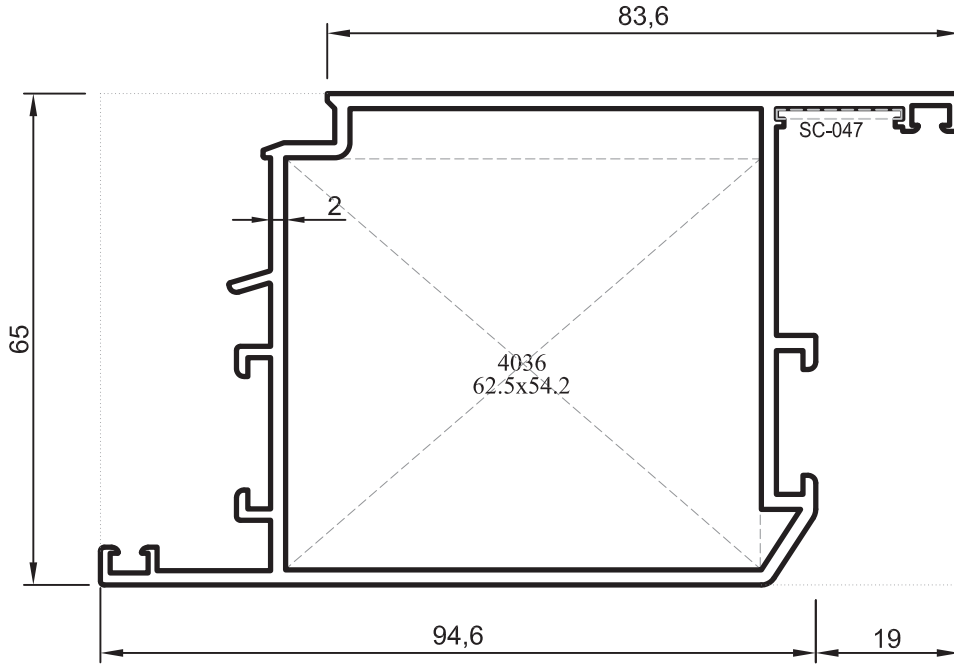

No : 5508

Kapı Kanadı
1.845 kg/m

$$J_x = 37,50 \text{ cm}^4$$
$$J_y = 74,51 \text{ cm}^4$$

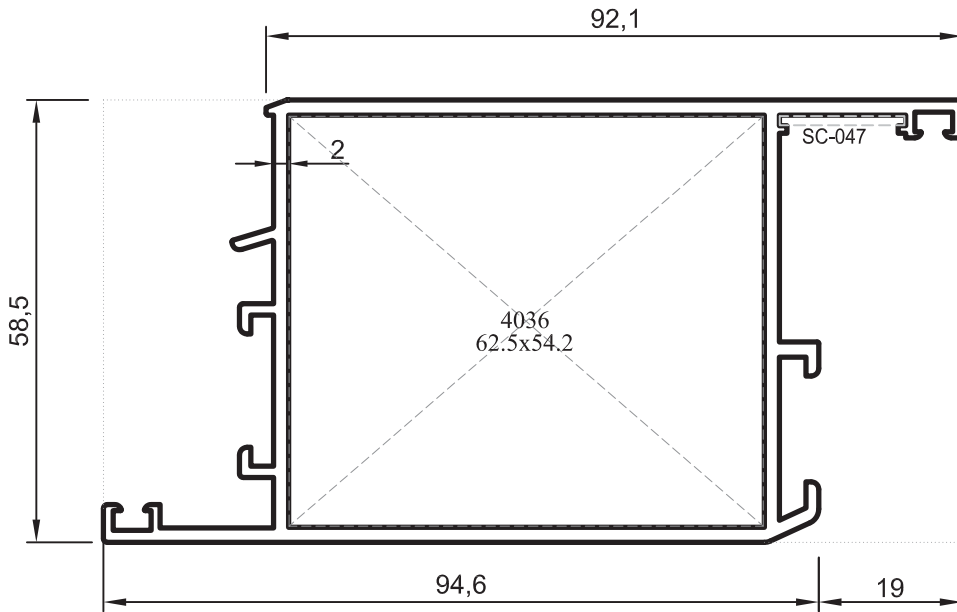

No : 5517

Düz Kapı Kanadı
1.770 kg/m

$$J_x = 31,83 \text{ cm}^4$$
$$J_y = 68,89 \text{ cm}^4$$

- Profiller
- Profiles

Yalıtımsız Kapı-Pencere Serisi

Kalın ve İnce Seri Profiller (2 mm-1,5 mm)

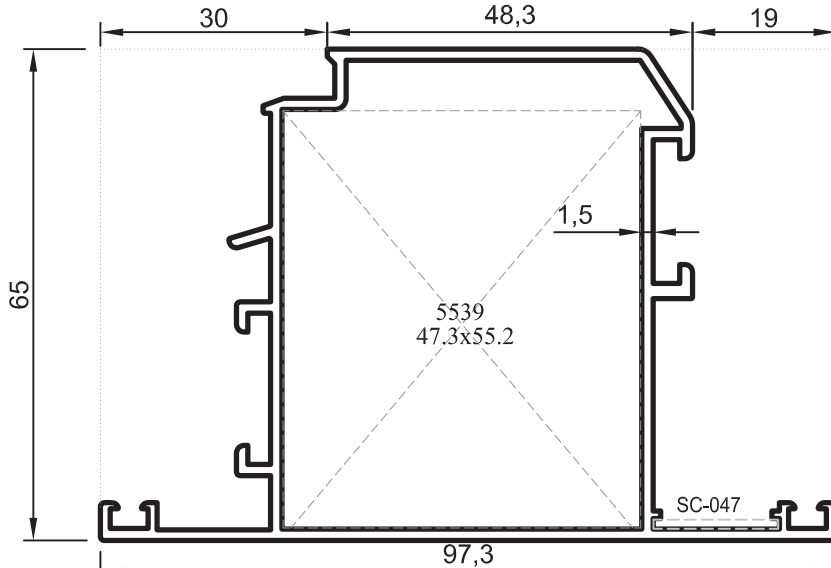

No : 7324

Dışa Açılır
Geniş Kanat
1,330 kg/m

$$J_x = 29,06 \text{ cm}^4$$

$$J_y = 33,43 \text{ cm}^4$$

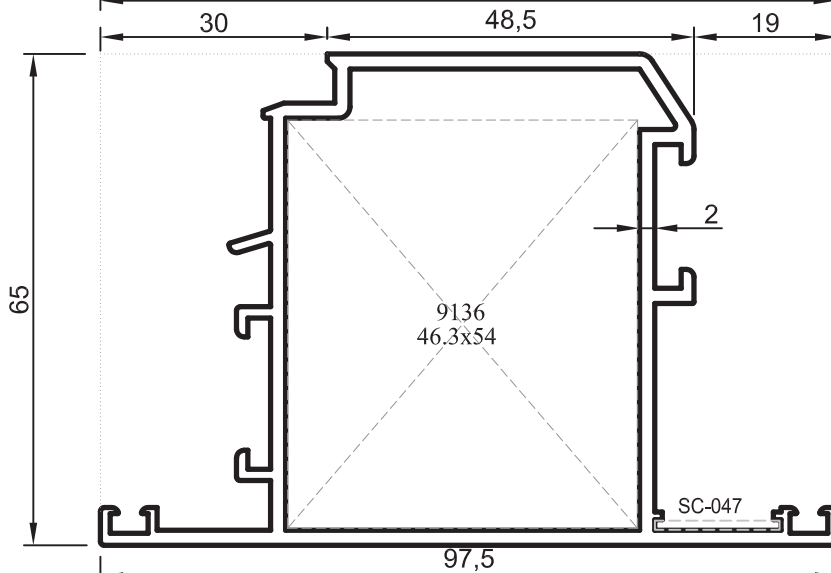

No : 7324/B

Dışa Açılır
Geniş Kanat
1,675 kg/m

$$J_x = 36,57 \text{ cm}^4$$

$$J_y = 40,62 \text{ cm}^4$$

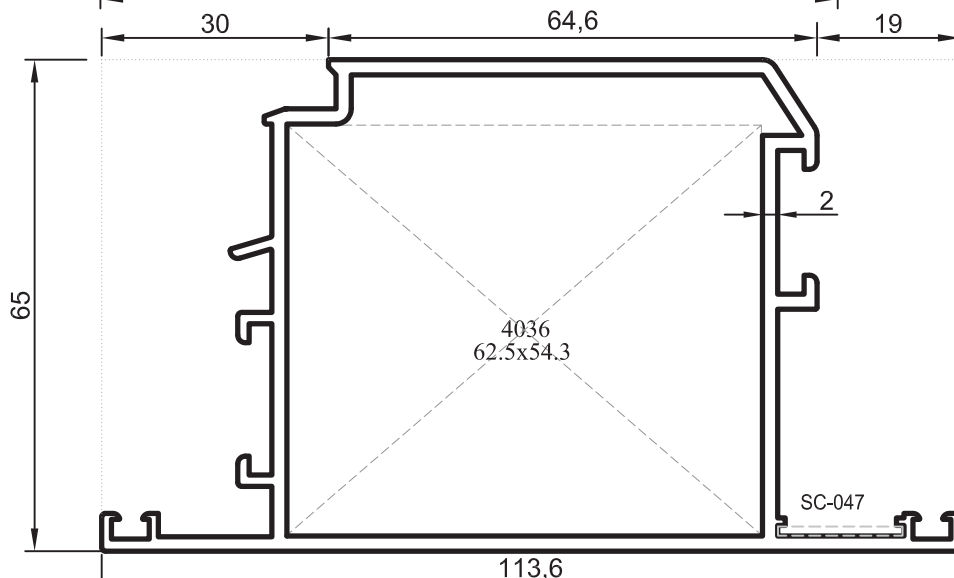

No : 5514

Dışa Açılır
Kapı Kanadı
1.845 kg/m

$$J_x = 43,67 \text{ cm}^4$$

$$J_y = 66,85 \text{ cm}^4$$

Uyarı: Profil ağırlıklarımız teorik olup; teslim anındaki tartımız geçerlidir. Warning: the weights of profile is theoretical, weighting at the time of

- Profiller
- Profiles

Yalıtımsız Kapı-Pencere Serisi

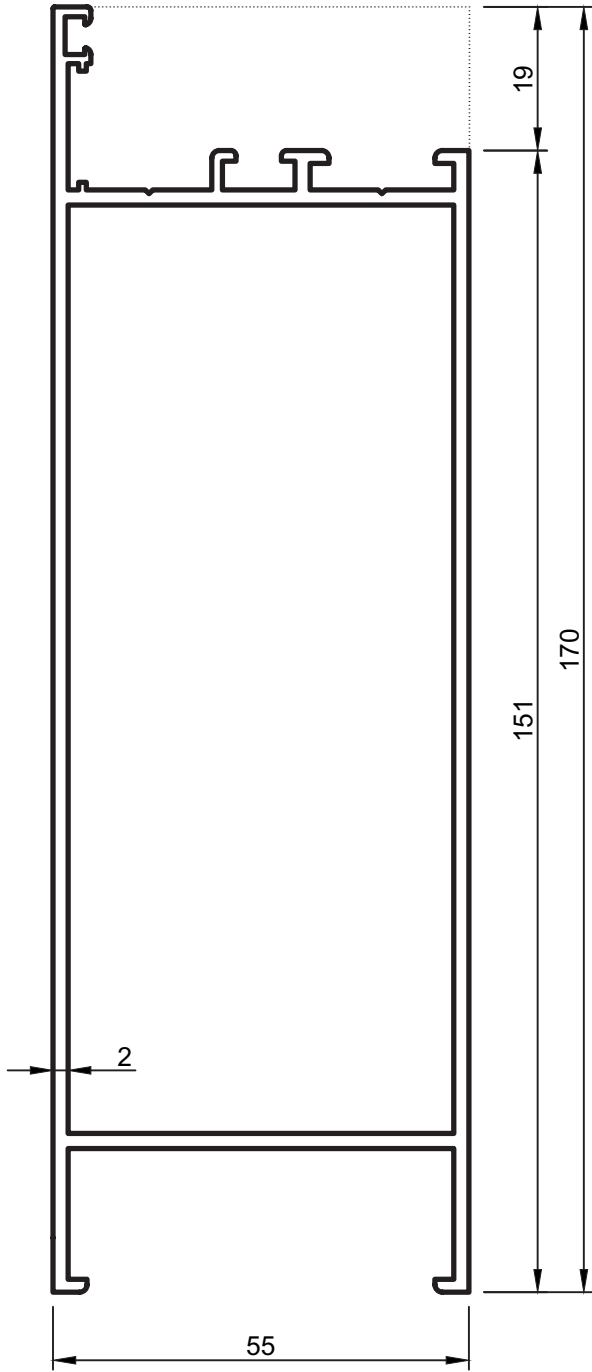

No : 5513

Etek
2,420 kg/m

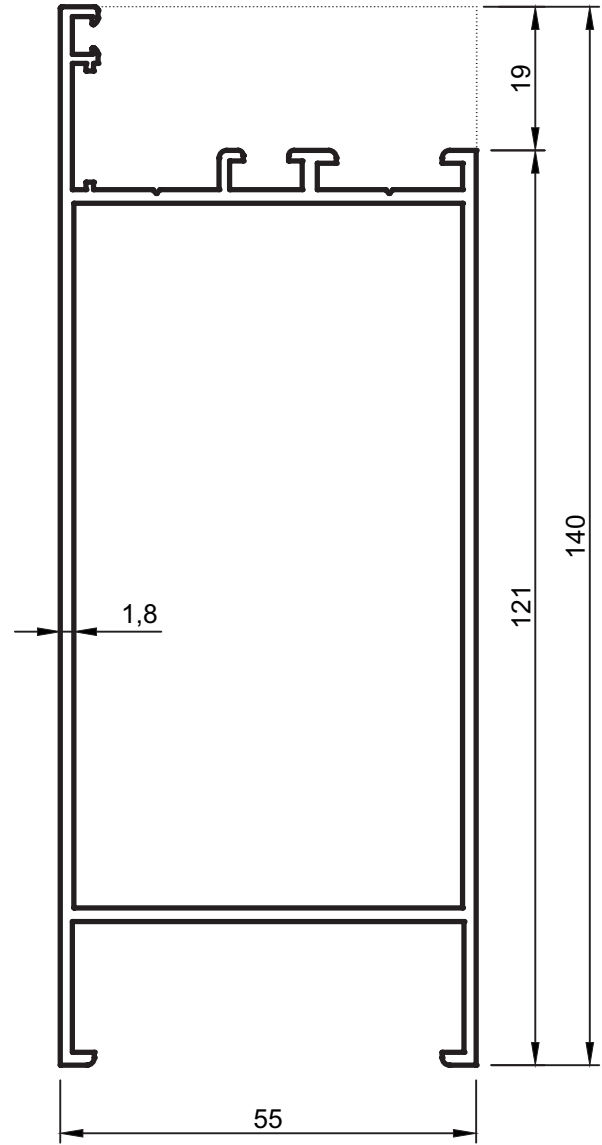

No : 7353

Etek
1,890 kg/m

- Profiller
- Profiles

Yalıtımsız Kapı-Pencere Serisi

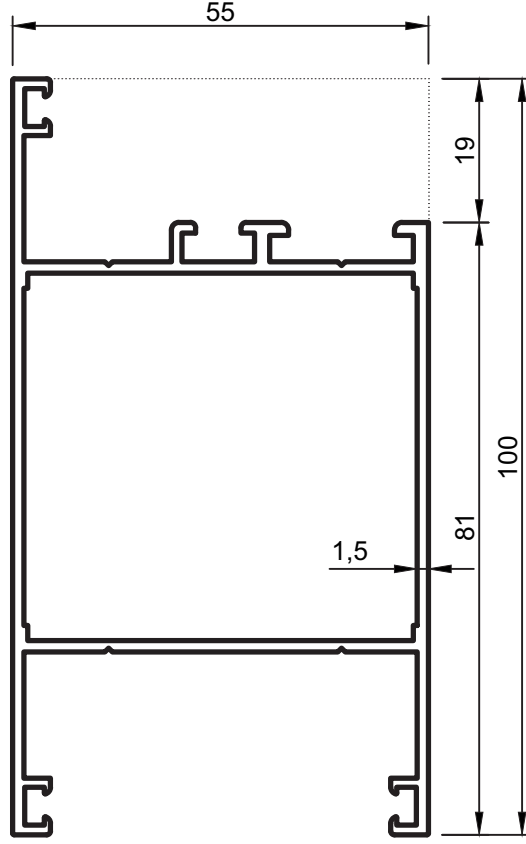

No : 7326

Etek
1,350 kg/m

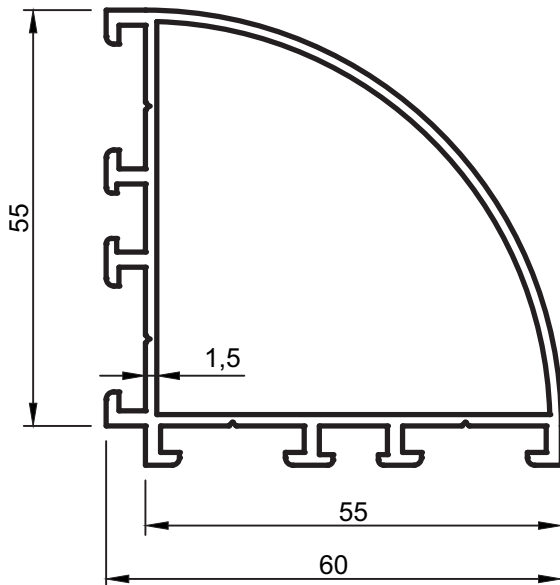

No : 11 271

90° Köşe Dönüş Profili
1,110 kg/m

- Profiller
- Profiles

Yalıtımsız Kapı-Pencere Serisi

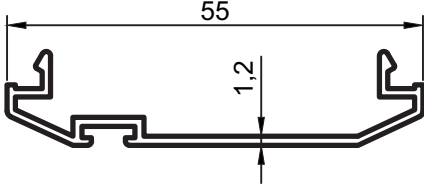

No : 5520

Çarpma Kapı Adaptörü
0,285 kg/m

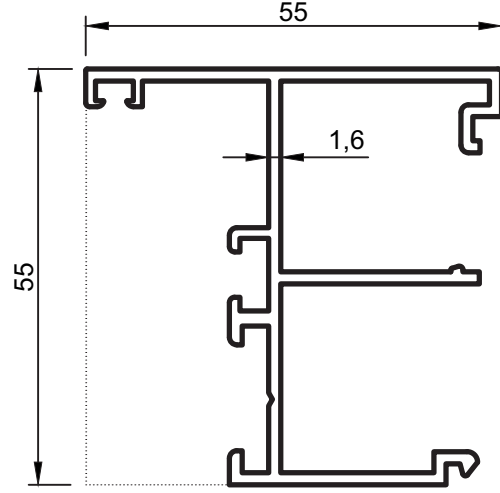

No : 5518

Çift Kapı Adaptörü
0,915 kg/m
(içe veya dışa açılır kapı)

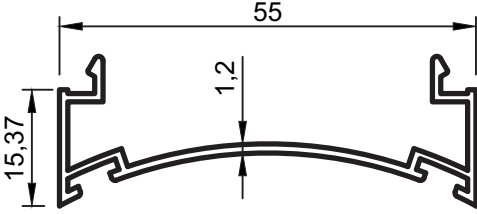

No : 5540

Çarpma Kapı Adaptörü
0,360 kg/m

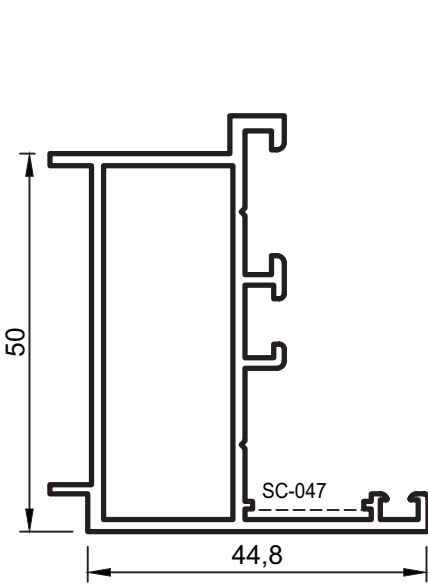

No : 5529

Dışa Açılır Kapı Adaptörü
0,900 kg/m

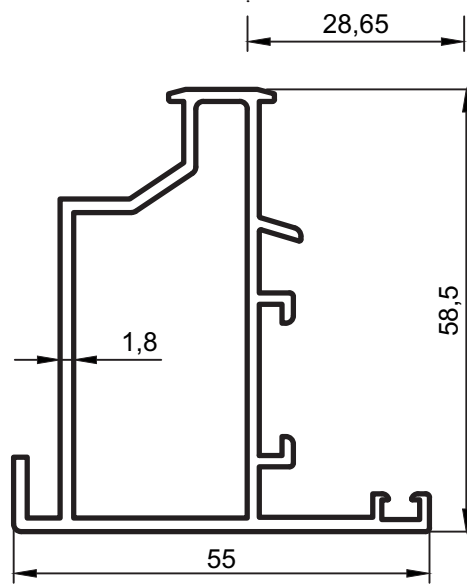

No : 5519

Pivot Adaptörü
1.040 kg/m

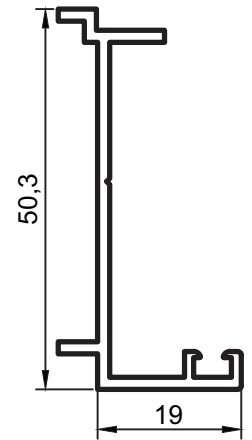

No : 5521

Kanat Adaptörü
0,405 kg/m

- Profiller
- Profiles

Yalıtımsız Kapı-Pencere Serisi

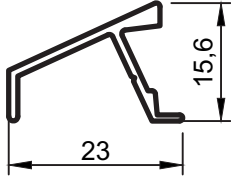

No : 1831

Damlalık
0,160 kg/m

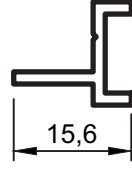

No : 5522

Kasa Adaptörü
0,140 kg/m

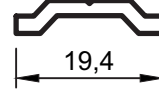

No : 877

İspanyolet tiji
0,130 kg/m

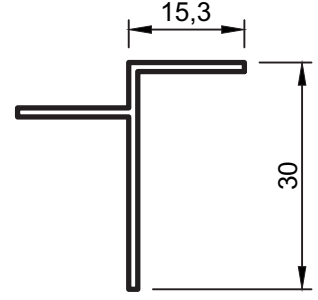

No : 5527

Kasa T 'si
0,200 kg/m

Cam Çıtaları

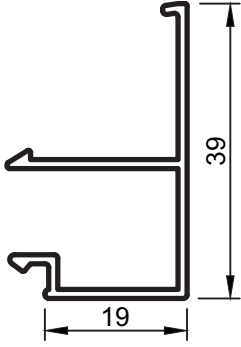

No : 5525

Cam Çıtası
0,310 kg/m

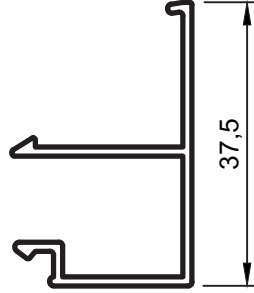

No : 5570

Cam Çıtası
0,305 kg/m

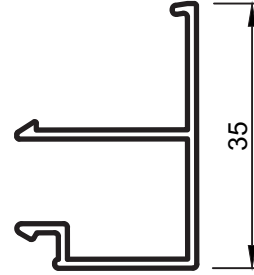

No : 310

Cam Çıtası
0,295 kg/m

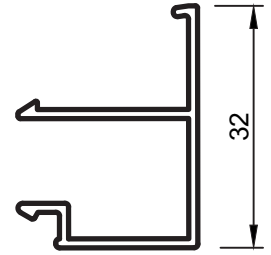

No : 342

Cam Çıtası
0,285 kg/m

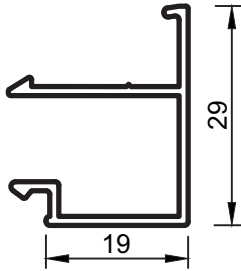

No : 5599

Cam Çıtası
0,275 kg/m

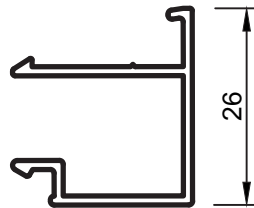

No : 397

Cam Çıtası
0,265 kg/m

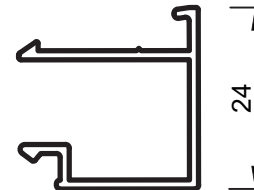

No : 5524

Cam Çıtası
0,260 kg/m

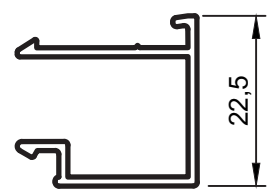

No : 5576

Cam Çıtası
0,260 kg/m

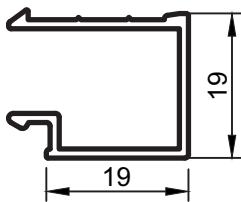

No : 344

Cam Çıtası
0,245 kg/m

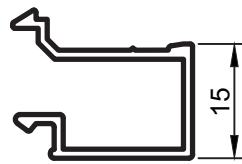

No : 5526

Cam Çıtası
0,240 kg/m

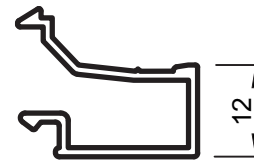

No : 5536

Cam Çıtası
0,230 kg/m

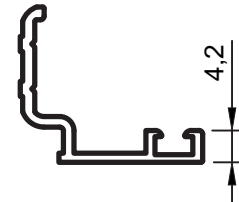

No : 5523

Etek Tırnağı ve cam çıtası
0,185 kg/m

Uyarı: Profil ağırlıklarımız teorik olup, teslim anındaki tartımlarımız geçerlidir. Warning: the weights of profile is theoretical, weighting at the time of delivery are valid.

• CAM VE FİTİL TABLOSU

Yalıtımsız Kapı-Pencere Serisi



- Profiller
- Profiles

Sistem Seri -Yalıtımlı Kapı-Pencere Serisi

RESİM PICTURE	PROFİL NO PROFILE NO	PROFİLİN İSMİ PROFILE NAME	AĞIRLIK WEIGHT (kg/m)	KULLANILAN PROFİL PROFILES USED	KESİM ÖLÇÜSÜ (mm) CUTTING DIMENSIONS
	339	27 mm Köşe Takozu Corner Cleat	6,230	5504, 5504/B, 5506, 5506/B, 8602	50,70
				5505, 5505/B 5516	54,20
	4036	62,50 mm Köşe Takozu Corner Cleat	9,800	5508 5514 5517	54,20
	4574	44,4 mm Köşe Takozu Corner Cleat	4,135	7354 7355	54,60

Dikkat : Köşeler preslenmeden önce mutlaka takozlarına epoksi tatbikatı uygulanmalıdır.

*** Köşe takozları boy olarak verilir.**

Uyarı: Profil ağırlıklarımız teorik olup; teslim anındaki tartımız geçerlidir.

Warning: the weights of profile is theoretical, weighting at the time of delivery are valid.

ölçek: 1/2

- Profiller
- Profiles

Sistem Seri -Yalıtımlı Kapı-Pencere Serisi

RESİM PICTURE	PROFİL NO PROFILE NO	PROFİLİN İSMİ PROFILE NAME	AĞIRLIK WEIGHT (kg/m)	KULLANILAN PROFİL PROFILES USED	KESİM ÖLÇÜSÜ (mm) CUTTING DIMENSIONS
	5539	47,3 mm Köşe Takozu Corner Cleat	8,310	5507, 5509, 5509/B, 5512	50,70
				5551	54,20
				7324 7325	55,20
	9084	13,2 mm Köşe Takozu Corner Cleat	2,370	5501, 5501/B, 5503, 5503/B, 7327	50,70
				5502, 5502/B, 5515, 5515/B,	54,20
	5550	Dik Bağlantı T Connection Profile	1,060	5501, 5501/B 5503, 5503/B	13,20
				5504, 5504/B 5506	27,00
				5507, 5509, 5509/B, 5512	47,30
				7326	48,30
				5510	77,30
				5511	85,30
				7353	92,90
				5513	122,50
	9136	46,3 mm Köşe Takozu Corner Cleat	4,030	7324/B	54,00

Dikkat : Köşeler preslenmeden önce mutlaka takozlarına epoksi tatbikatı uygulanmalıdır.

*** Köşe takozları boy olarak verilir.**

Uyarı: Profil ağırlıklarımız teorik olup; teslim anındaki tartımız geçerlidir.

Warning: the weights of profile is theoretical, weighting at the time of delivery are valid.

ölçek: 1/2

- Profiller
- Profiles

Sistem Seri -Yalıtımlı Kapı-Pencere Serisi

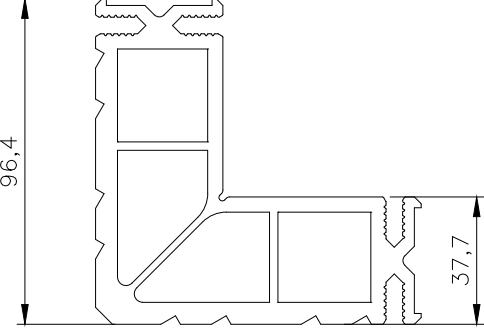
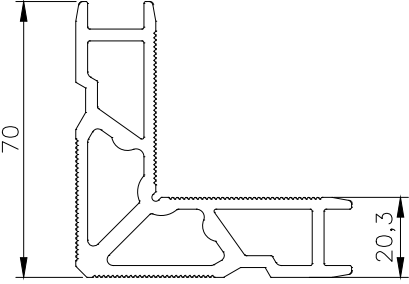
RESİM PICTURE	PROFİL NO PROFILE NO	PROFİLİN İSMİ PROFILE NAME	AĞIRLIK WEIGHT (kg/m)	KULLANILAN PROFİL PROFILES USED	KESİM ÖLÇÜSÜ (mm) CUTTING DIMENSIONS
	341 SC-954	37,7mm Köşe Takozu Corner Cleat	6,120	19517	55
	9133 SC-955	20,3 mm Köşe Takozu Corner Cleat	2,715	19518	54,5

Dikkat : Köşeler preslenmeden önce mutlaka takozlarına epoksi tatbikatı uygulanmalıdır.

*** Köşe takozları boy olarak verilir.**

Uyarı: Profil ağırlıklarımız teorik olup; teslim anındaki tartımız geçerlidir.

Warning: the weights of profile is theoretical, weighting at the time of delivery are valid.

ölçek: 1/2

S55
WINDOWS and DOORS
SYSTEM
SERIES DETAILS

S55
KAPI ve PENCERE SİSTEMİ
PRENSİP DETAYLAR

- Detaylar
- Details

Yalıtımsız Kapı-Pencere Serisi

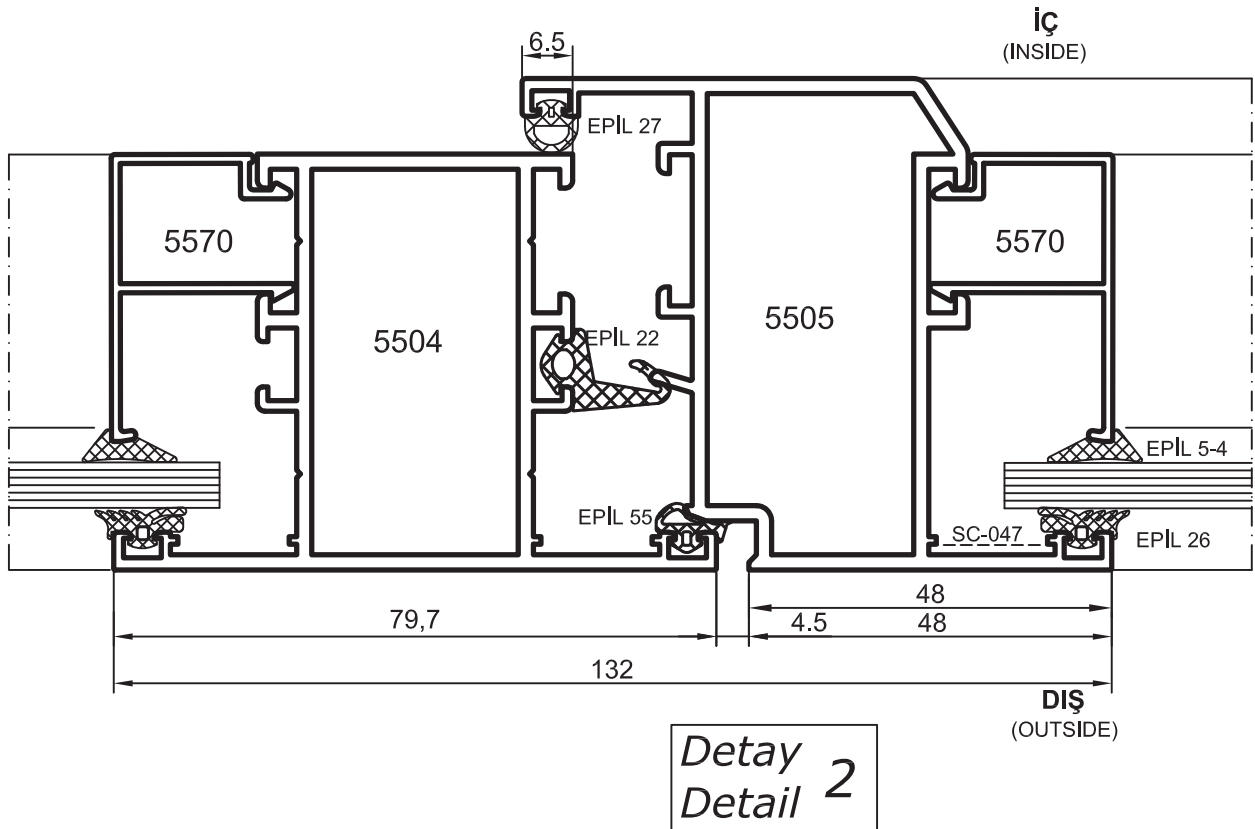
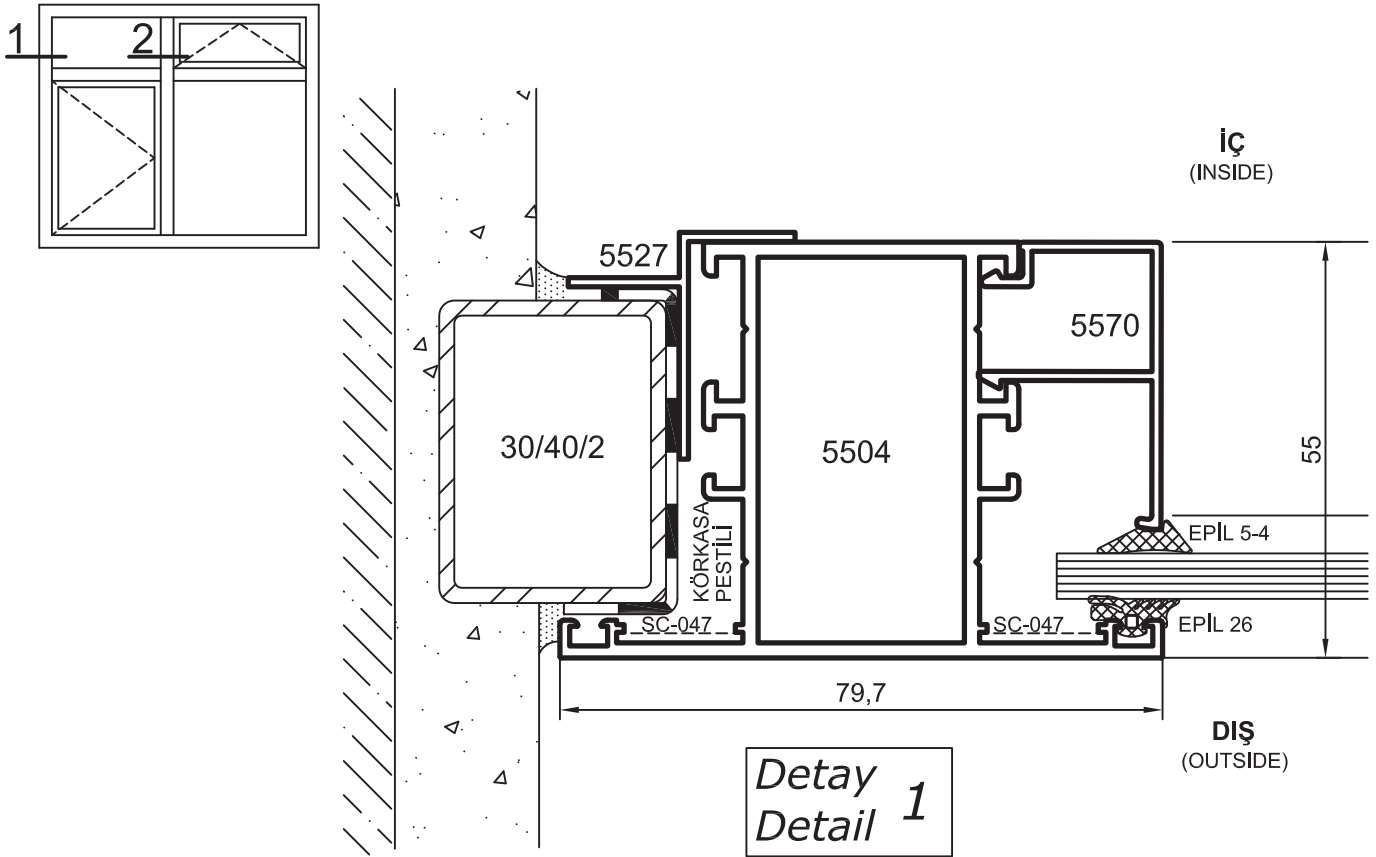

- Detaylar
- Details

Yalıtımsız Kapı-Pencere Serisi

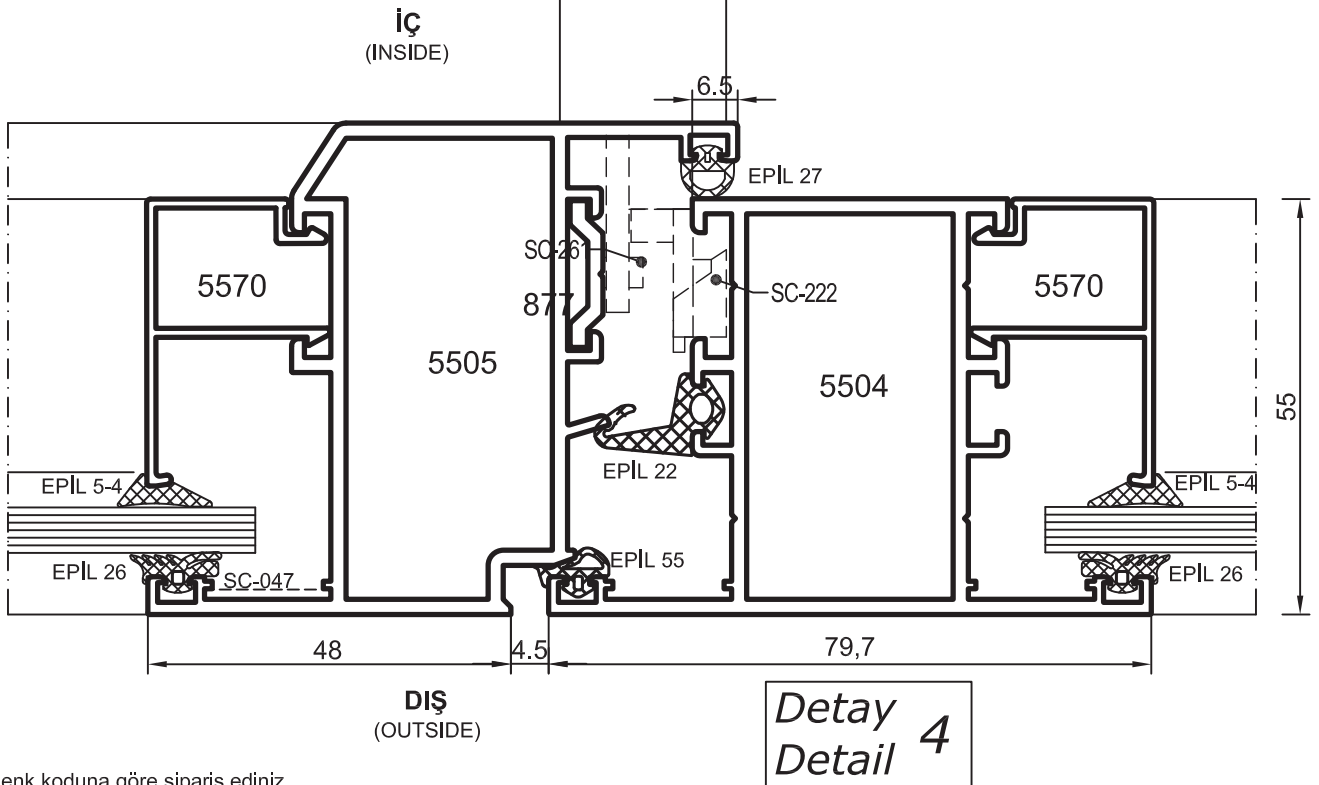
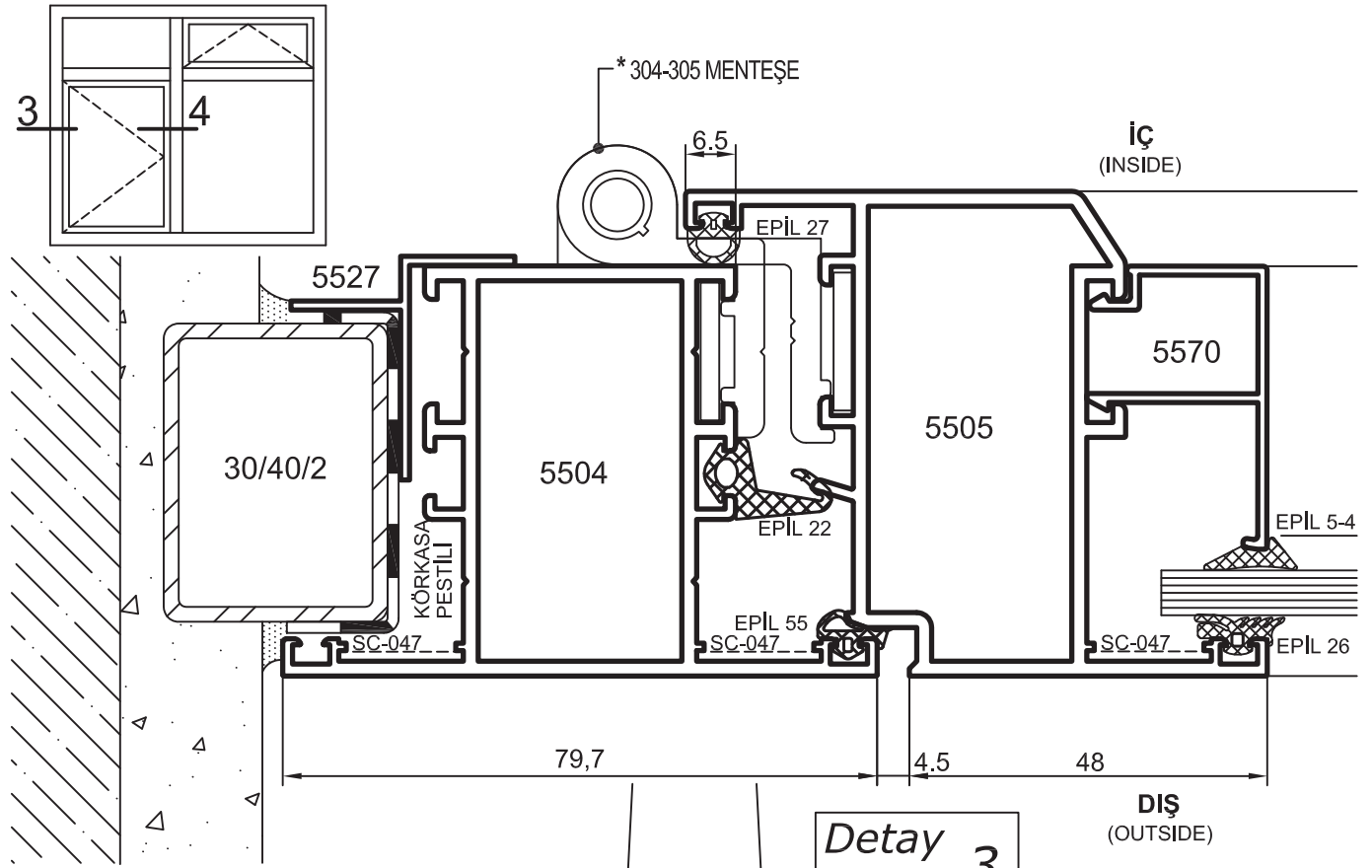

* Renk koduna göre sipariş ediniz.

- Detaylar
- Details

Yalıtımsız Kapı-Pencere Serisi

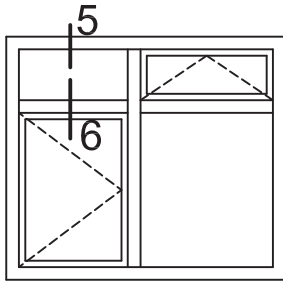

Detay
Detail 5

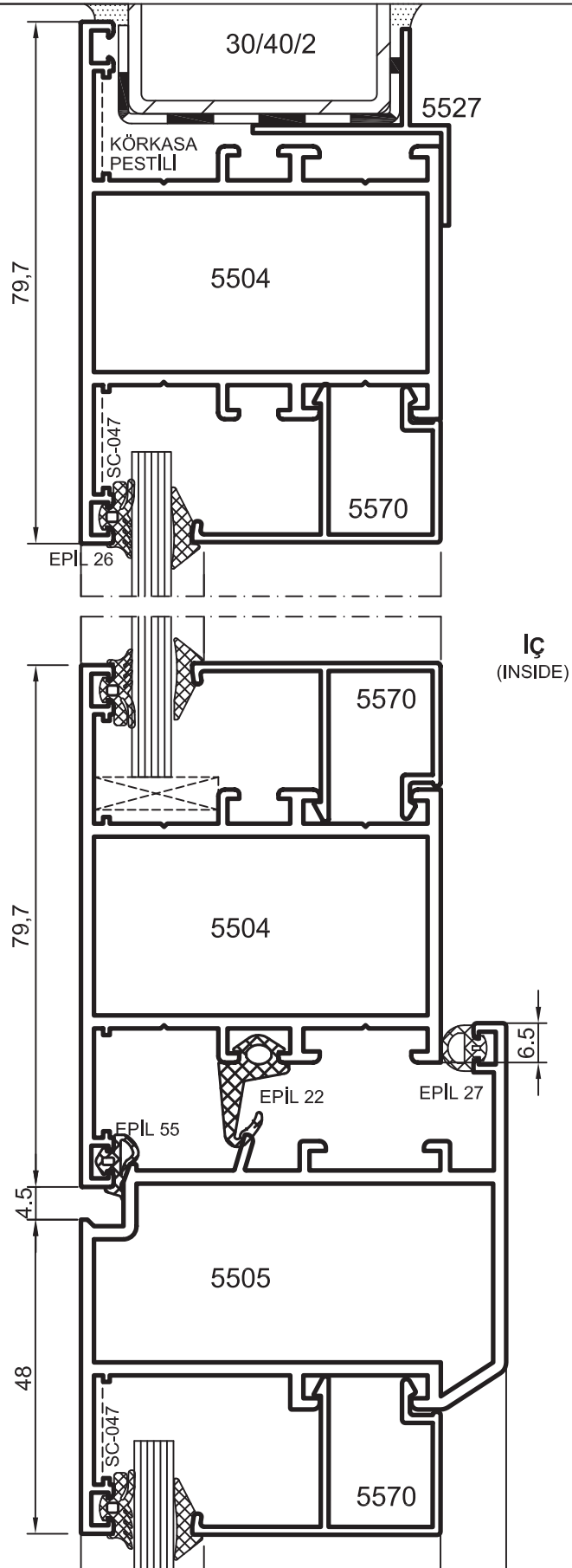

Detay
Detail 6

- Detaylar
- Details

Yalıtımsız Kapı-Pencere Serisi

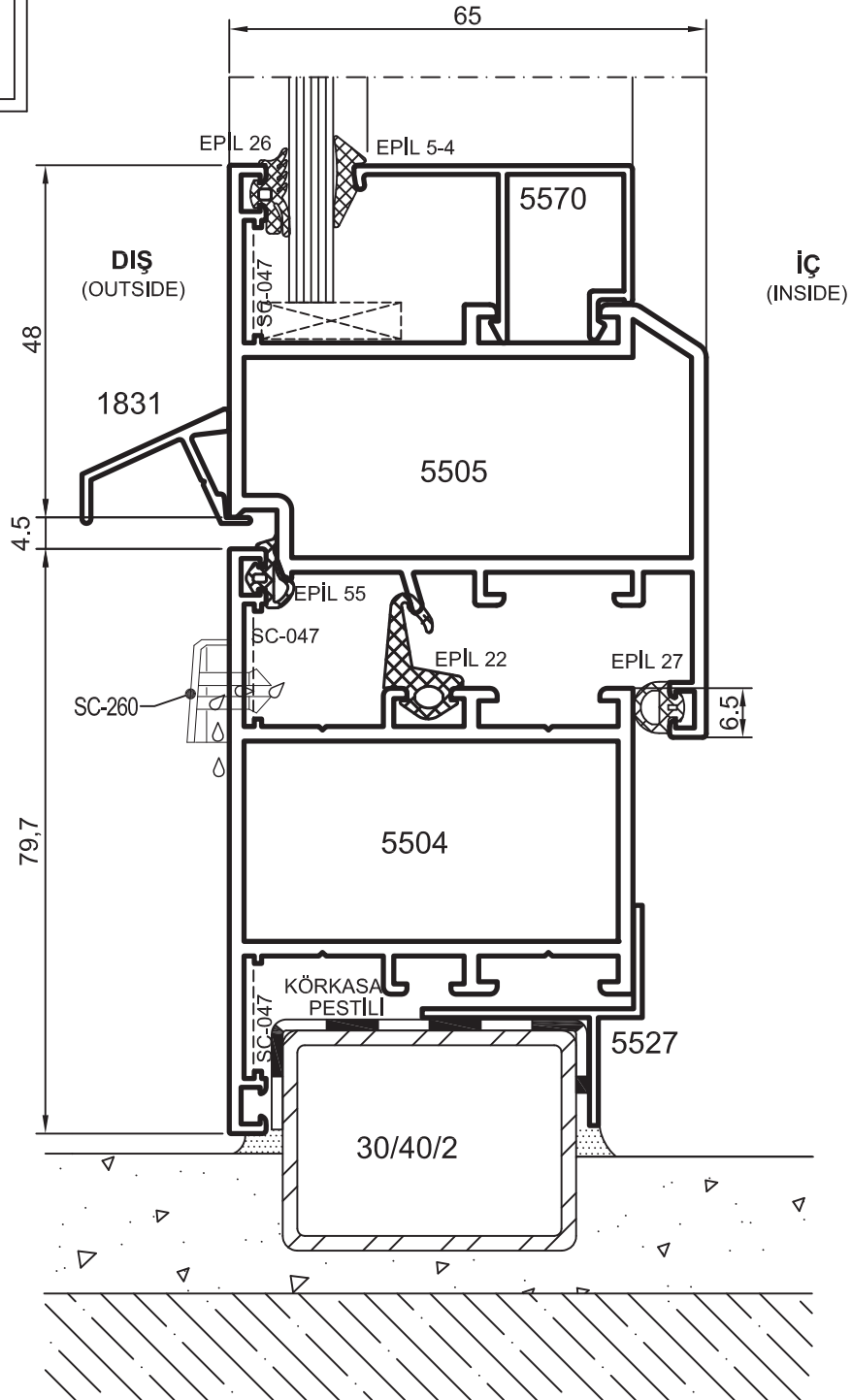
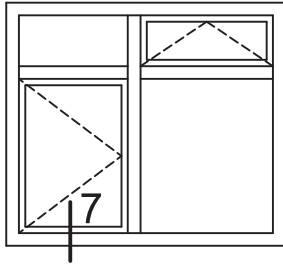

Detay 7
Detail 7

- Detaylar
- Details

Yalıtımsız Kapı-Pencere Serisi

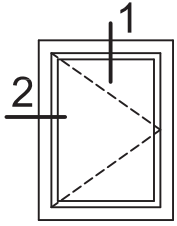

Detay
Detail 1

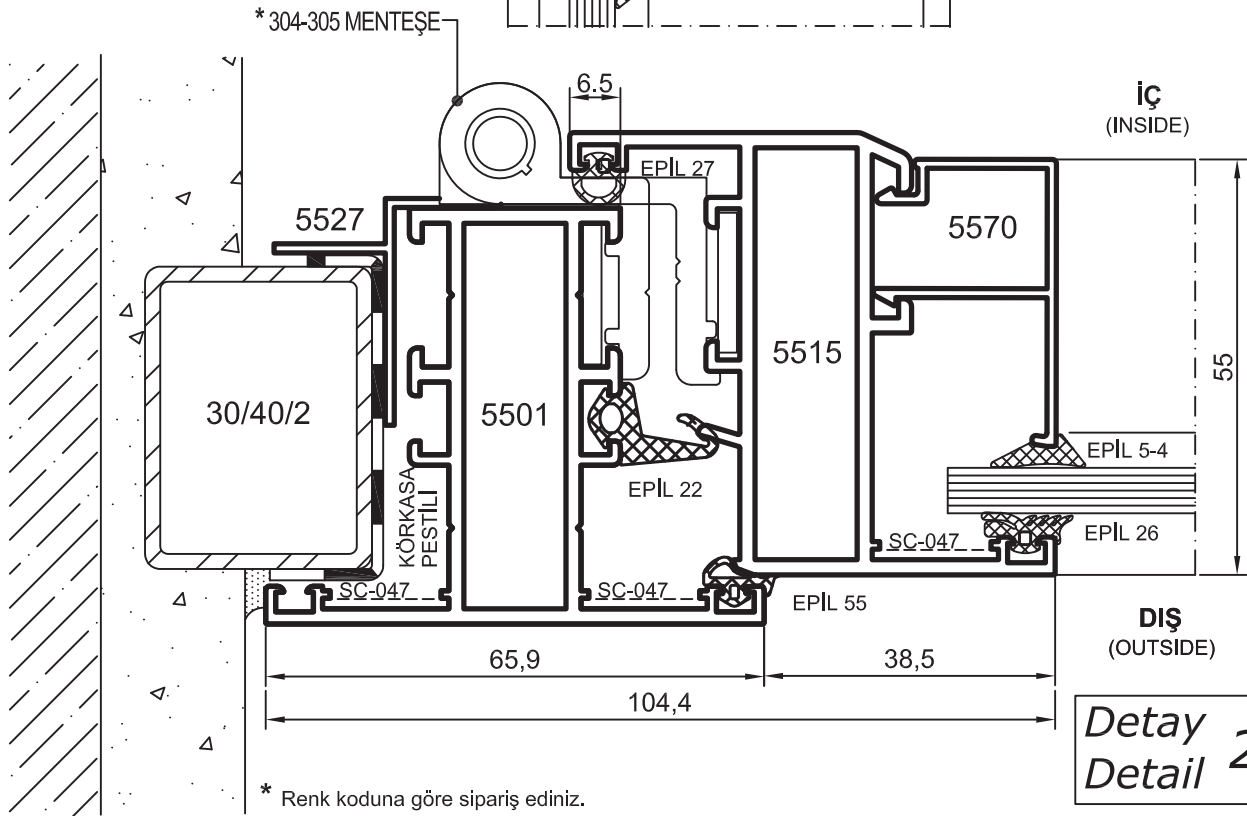
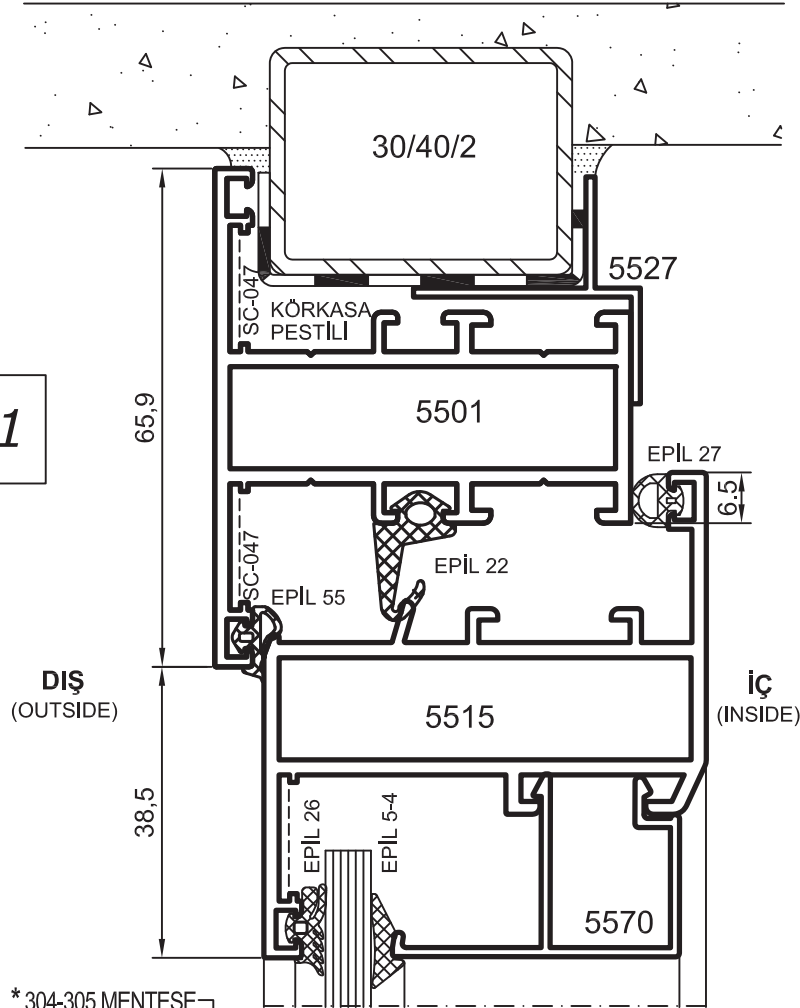

Detay
Detail 2

* Renk koduna göre sipariş ediniz.

- Detaylar
- Details

Yalıtımsız Kapı-Pencere Serisi

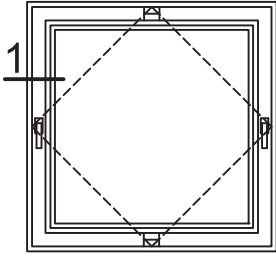

Pivot Window System Detail
Pivot Pencere Sistem Detayı

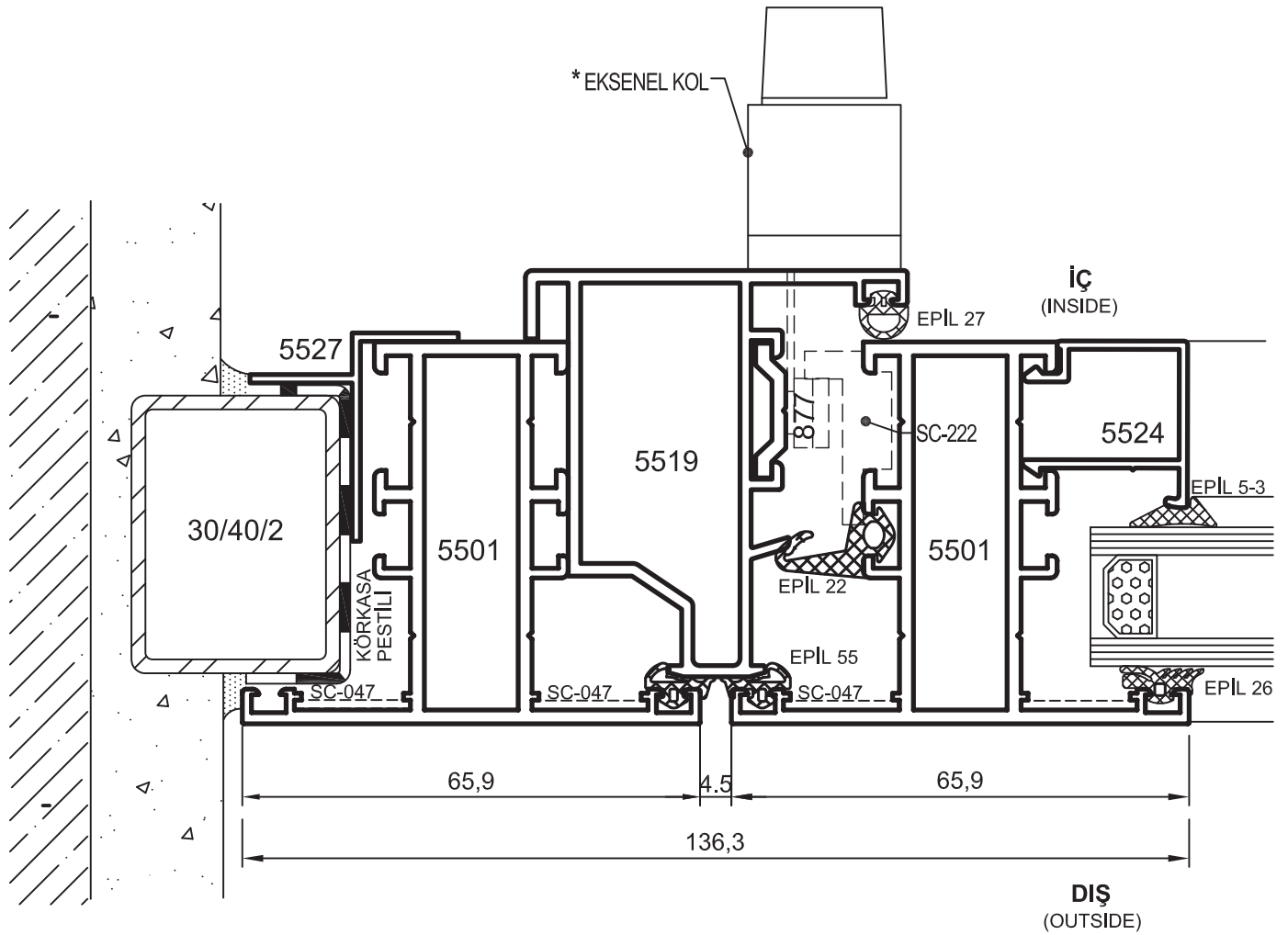

Detay 1
Detail 1

* Renk koduna göre sipariş ediniz.

- Detaylar
- Details

Yalıtımsız Kapı-Pencere Serisi

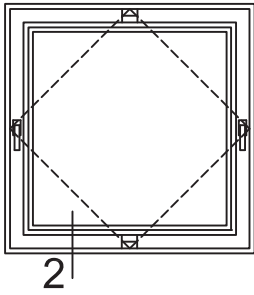

Pivot Window System Detail
Pivot Pencere Sistem Detayı

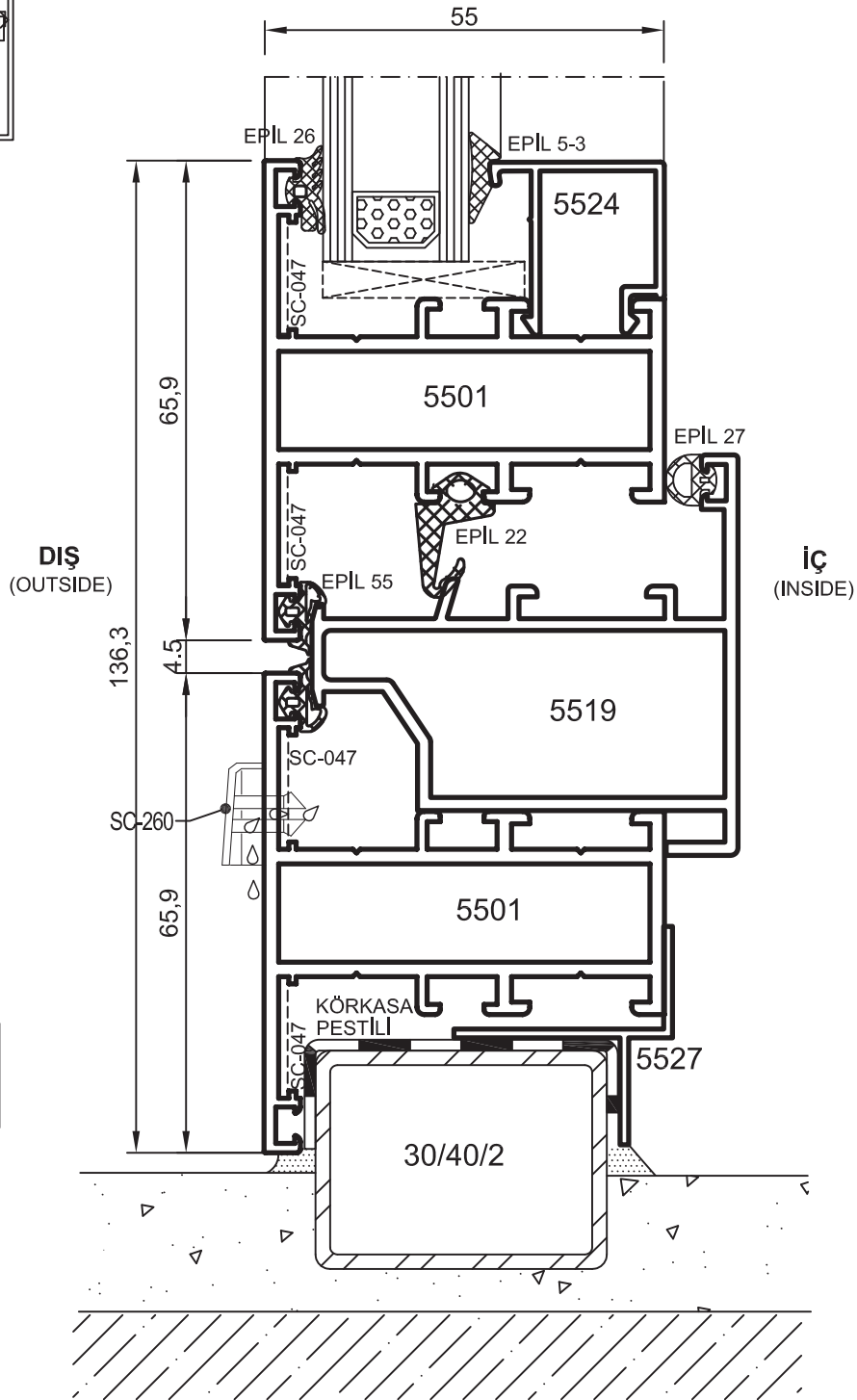

Detay
Detail 2

- Detaylar
- Details

Yalıtımsız Kapı-Pencere Serisi

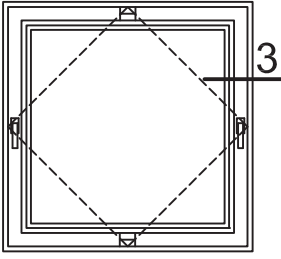

Pivot Window System Detail
Pivot Pencere Sistem Detayı

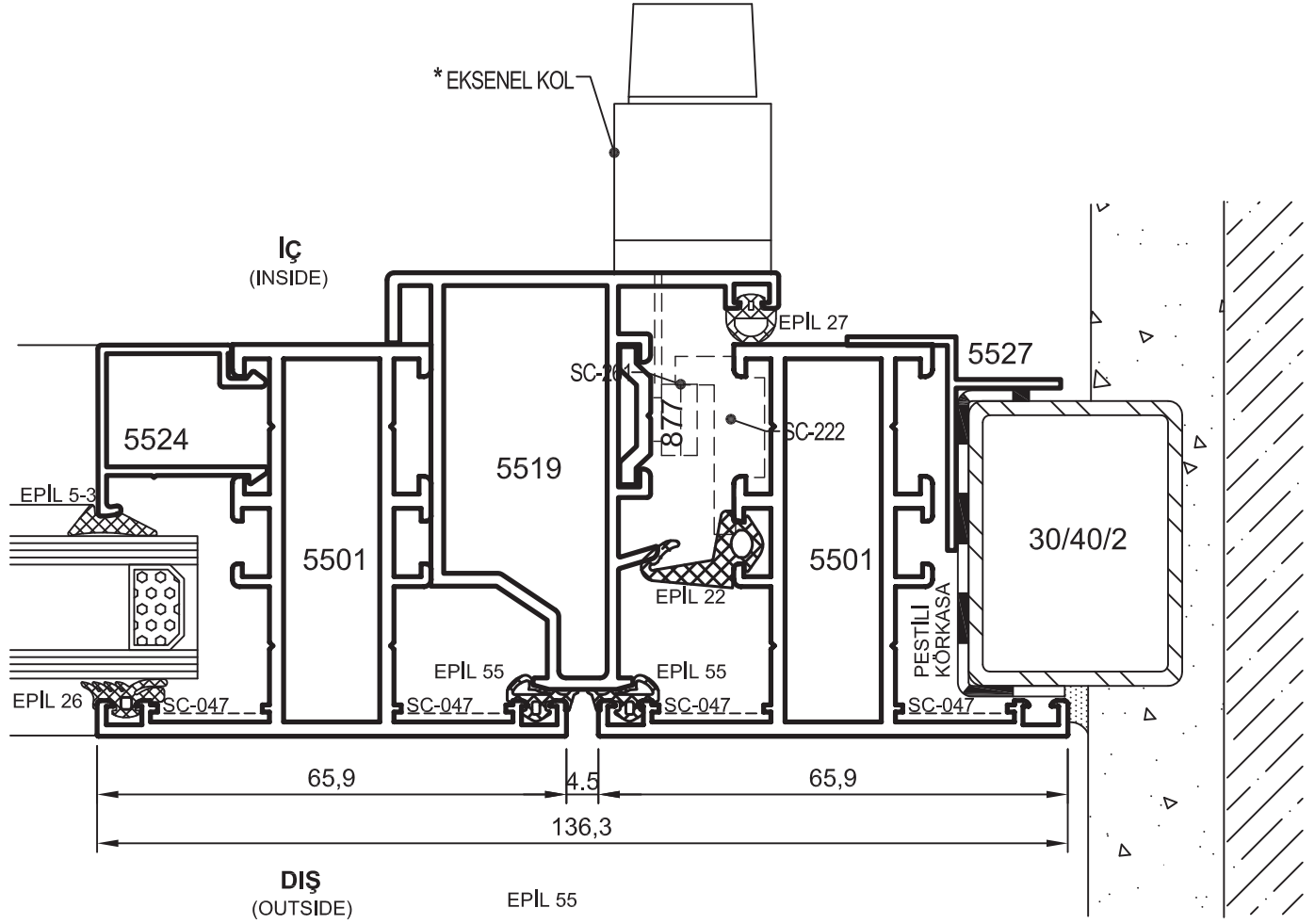

Detay 3
Detail 3

* Renk koduna göre sipariş ediniz.

- Detaylar
- Details

Yalıtımsız Kapı-Pencere Serisi

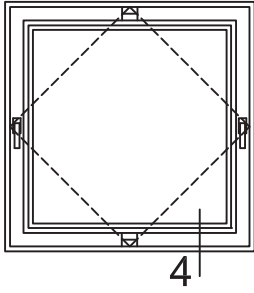

Pivot Window System Detail
Pivot Pencere Sistem Detayı

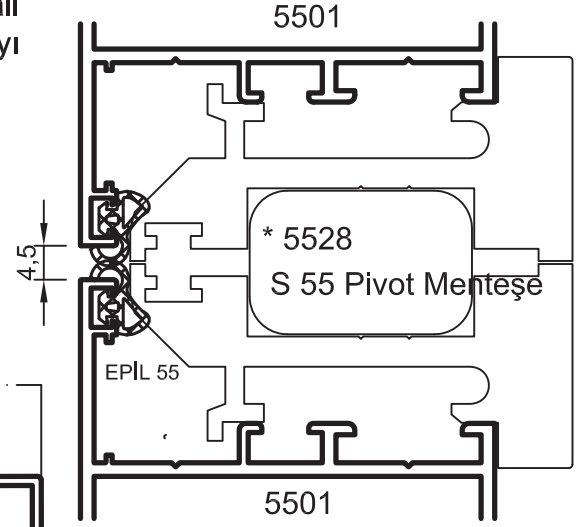

DIŞ
(OUTSIDE)

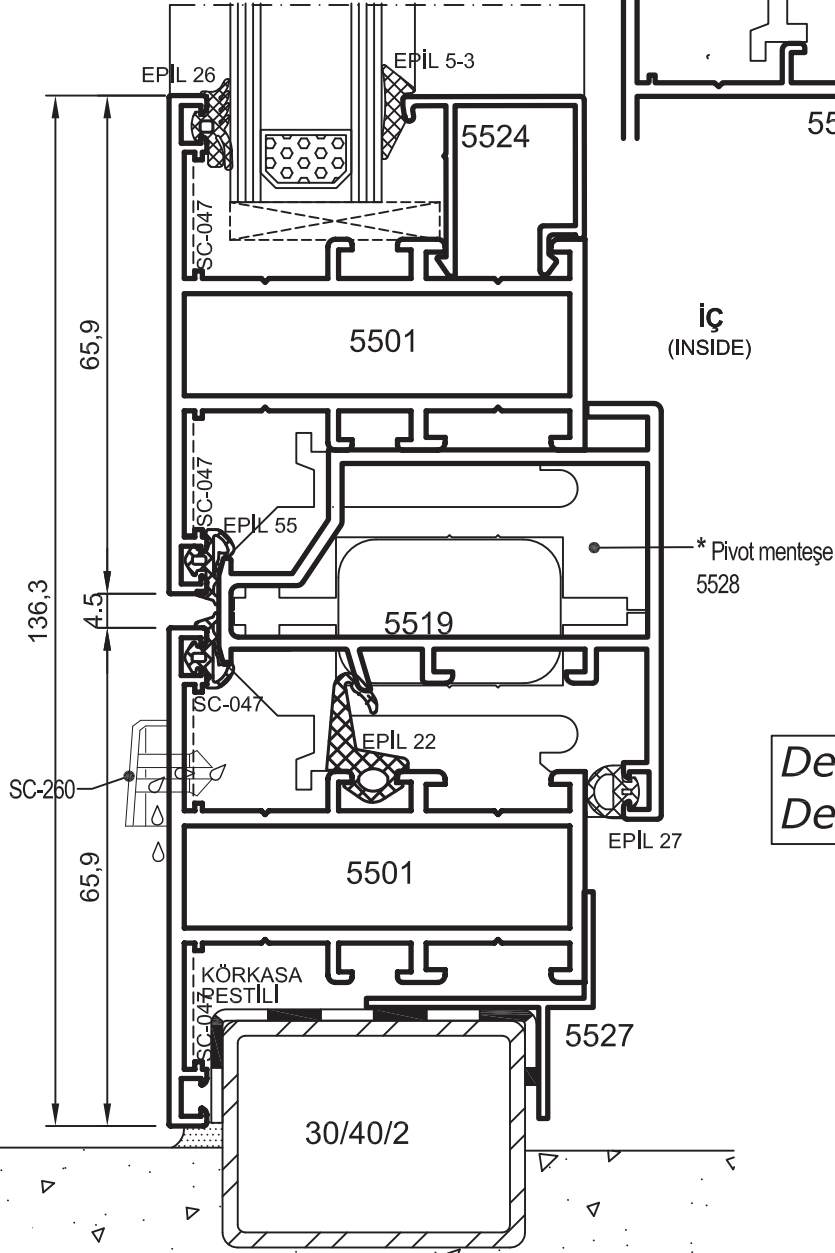

İÇ
(INSIDE)

Detay
Detail 4

* Renk koduna göre sipariş ediniz.

- Detaylar
- Details

Yalıtımsız Kapı-Pencere Serisi

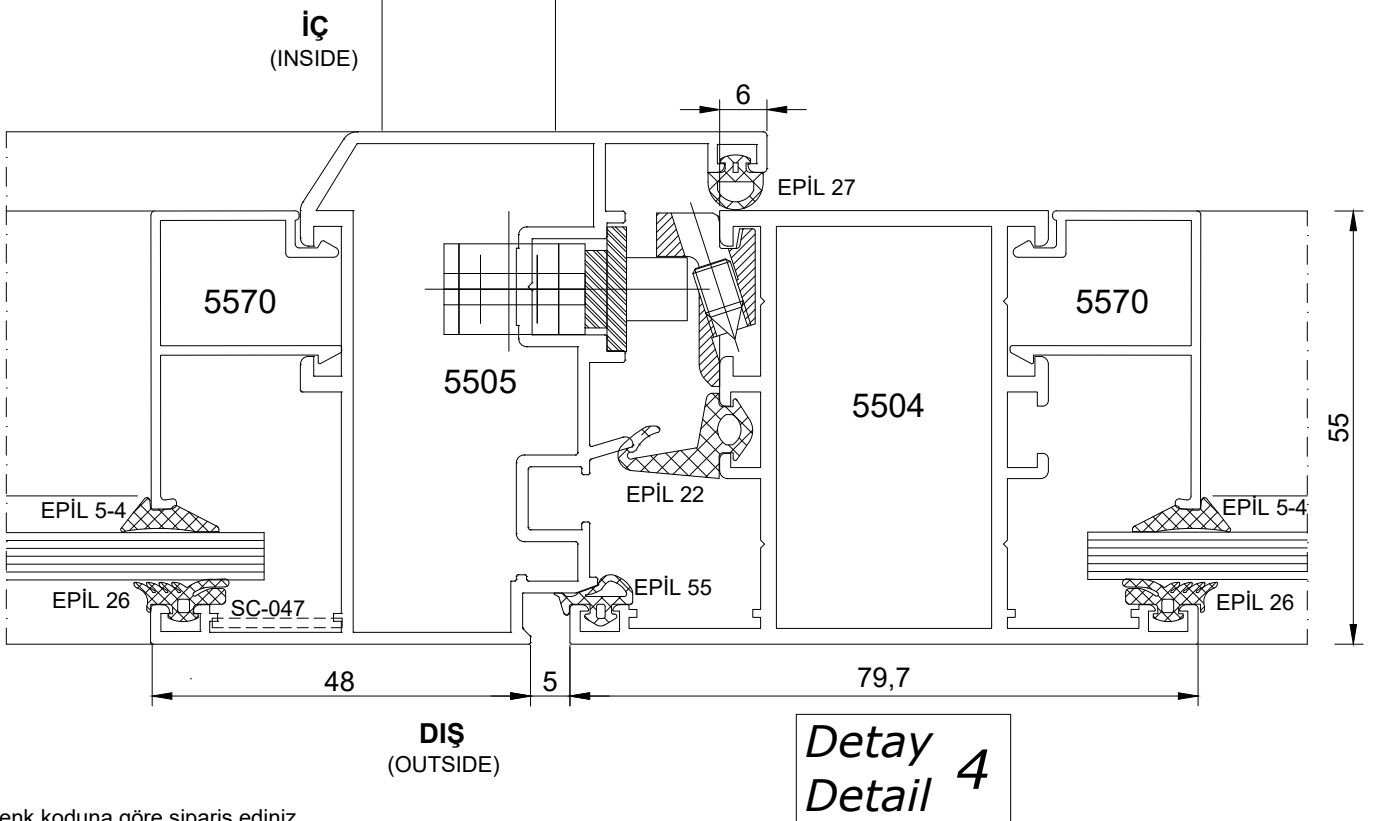
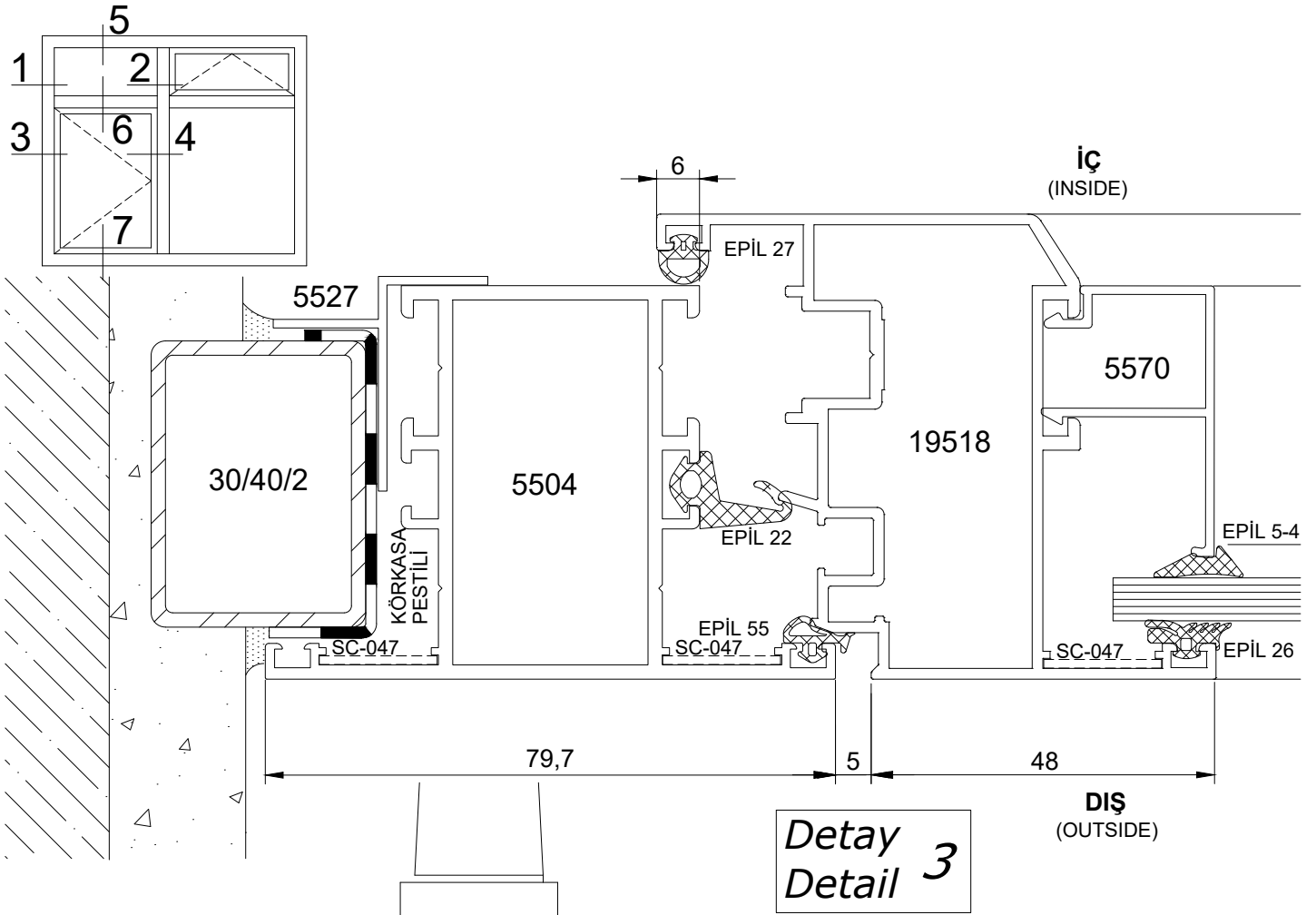

* Renk koduna göre sipariş ediniz.

- Detaylar
- Details

Yalıtımsız Kapı-Pencere Serisi

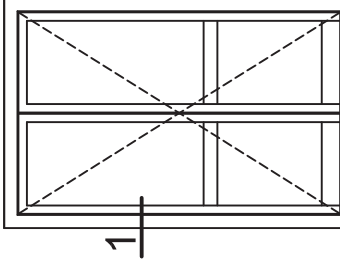

İÇE AÇILIR KAPI
DOOR - INSIDE OPENING

Detay 1
Detail

Kod : SFKM-55-071
FUGALI KAPAZLAMA MENTEŞE

İÇ
(INSIDE)

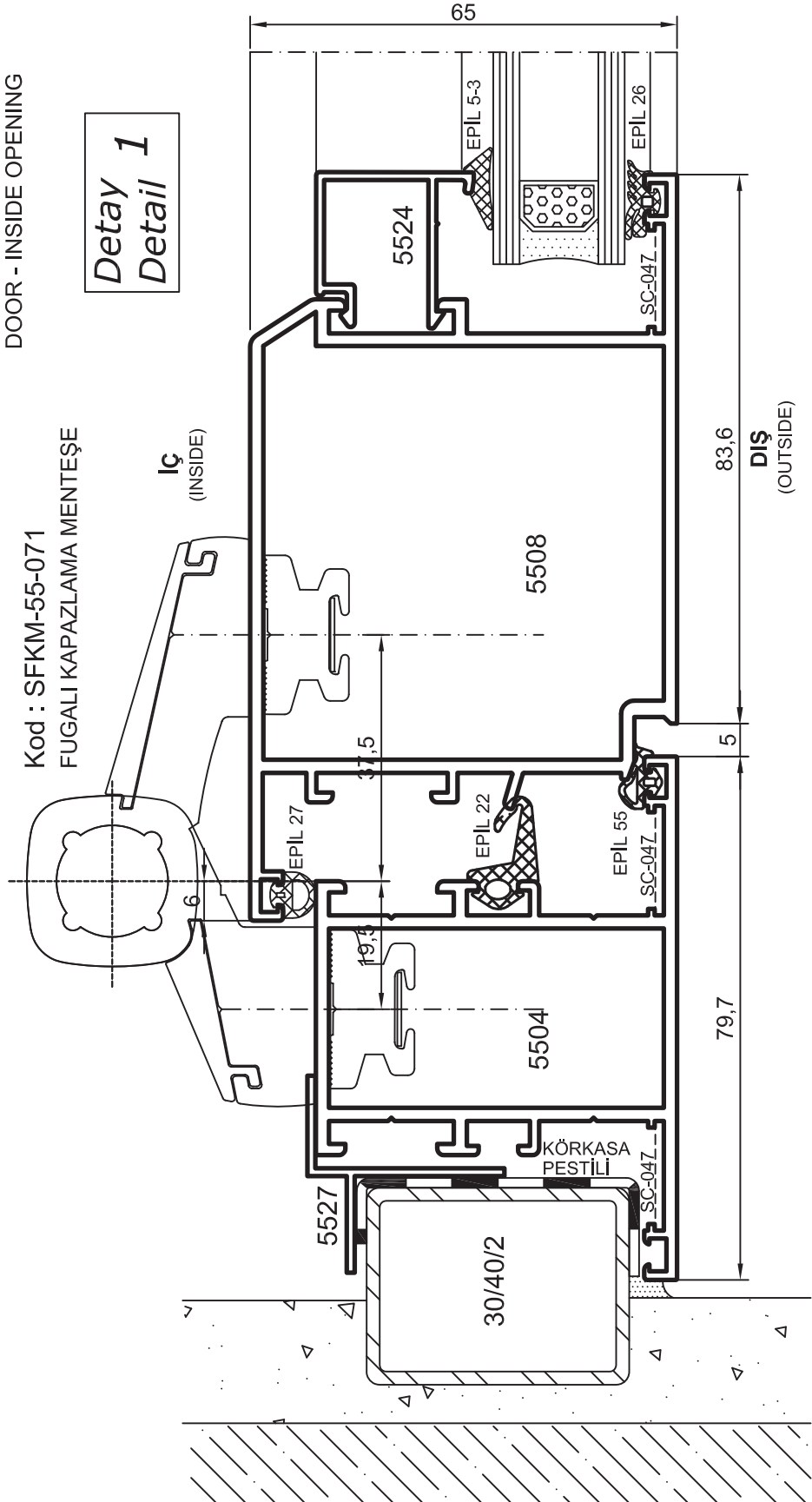

83,6
DIŞ
(OUTSIDE)

79,7

5

37,5

19,3

6

30/40/2

5504

5508

5524

65

EPİL 5-3

EPİL 26

SC-047

EPİL 27

EPİL 22

EPİL 55

SC-047

SC-047

SC-047

SC-047

- Detaylar
- Details

Yalıtımsız Kapı-Pencere Serisi

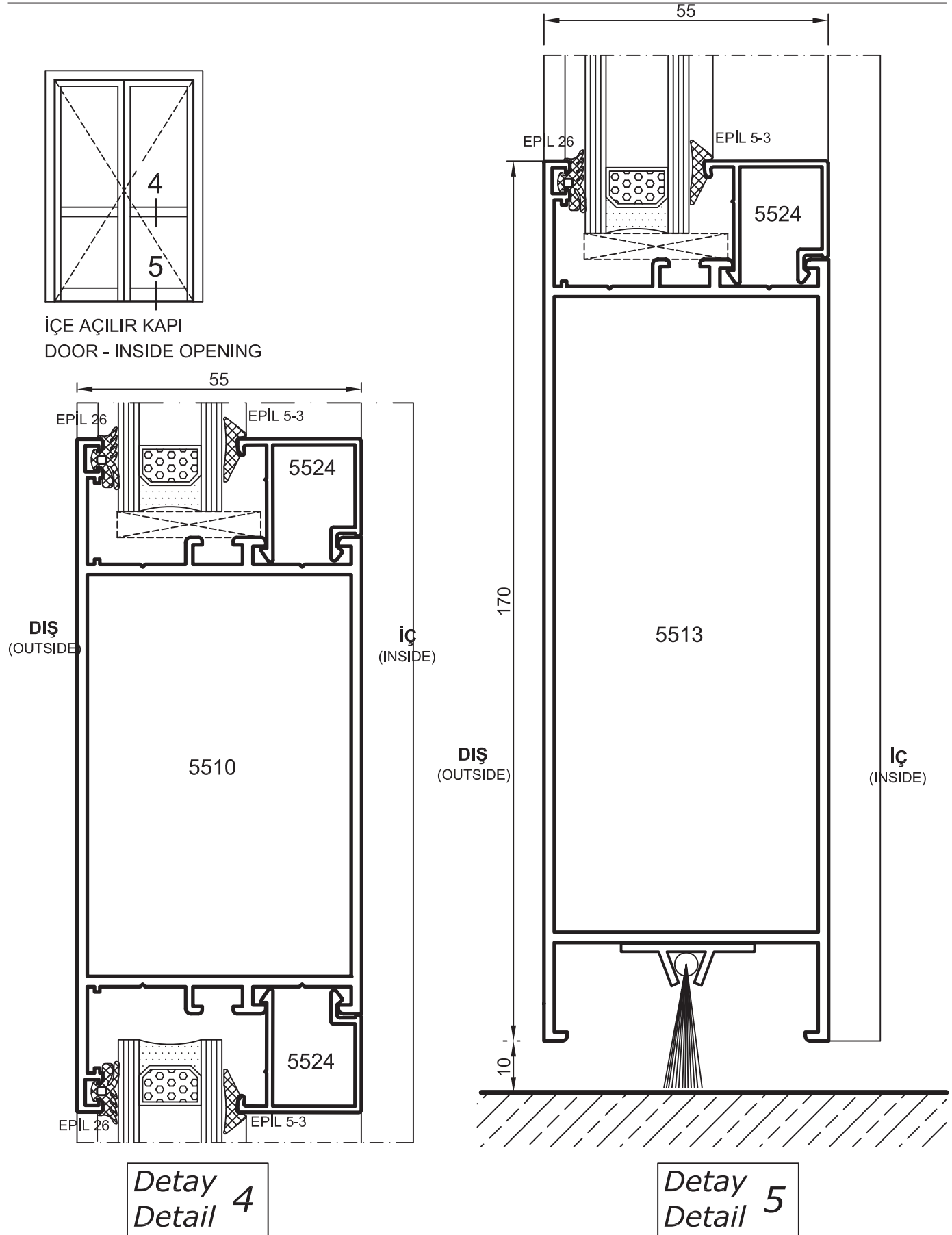

- Detaylar
- Details

Yalıtımsız Kapı-Pencere Serisi

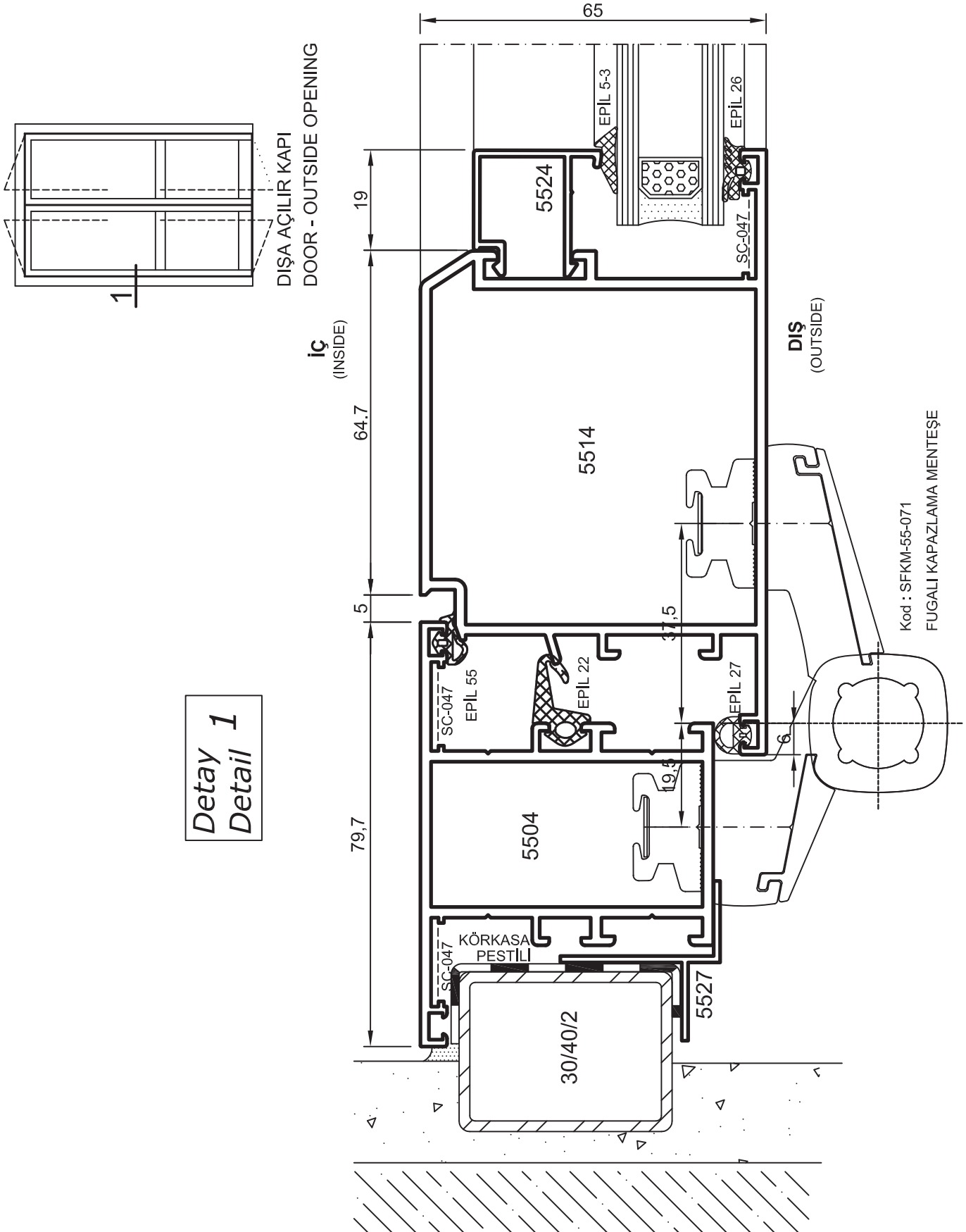

- Detaylar
- Details

Yalıtımsız Kapı-Pencere Serisi

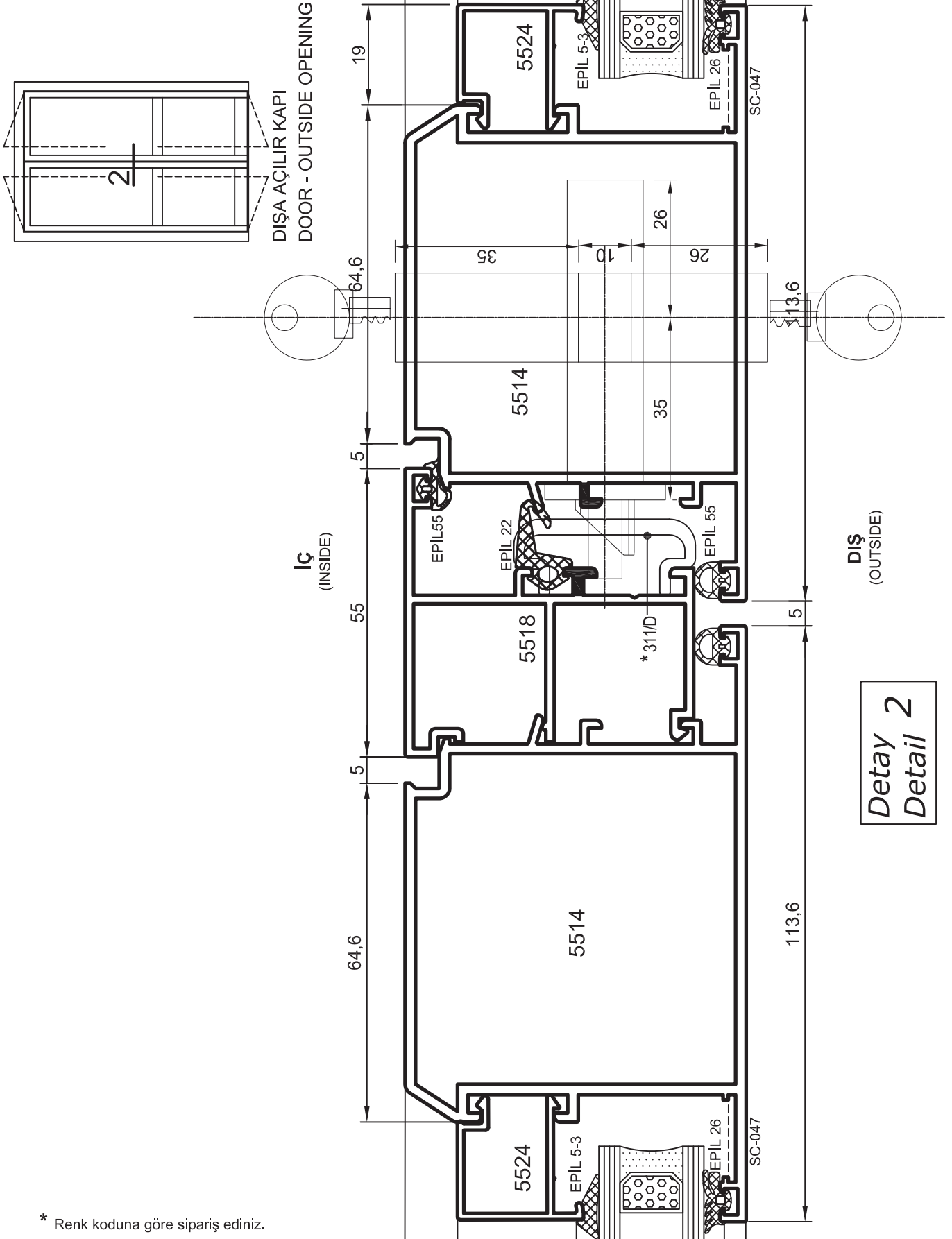

* Renk koduna göre sipariş ediniz.

- Detaylar
- Details

Yalıtımsız Kapı-Pencere Serisi

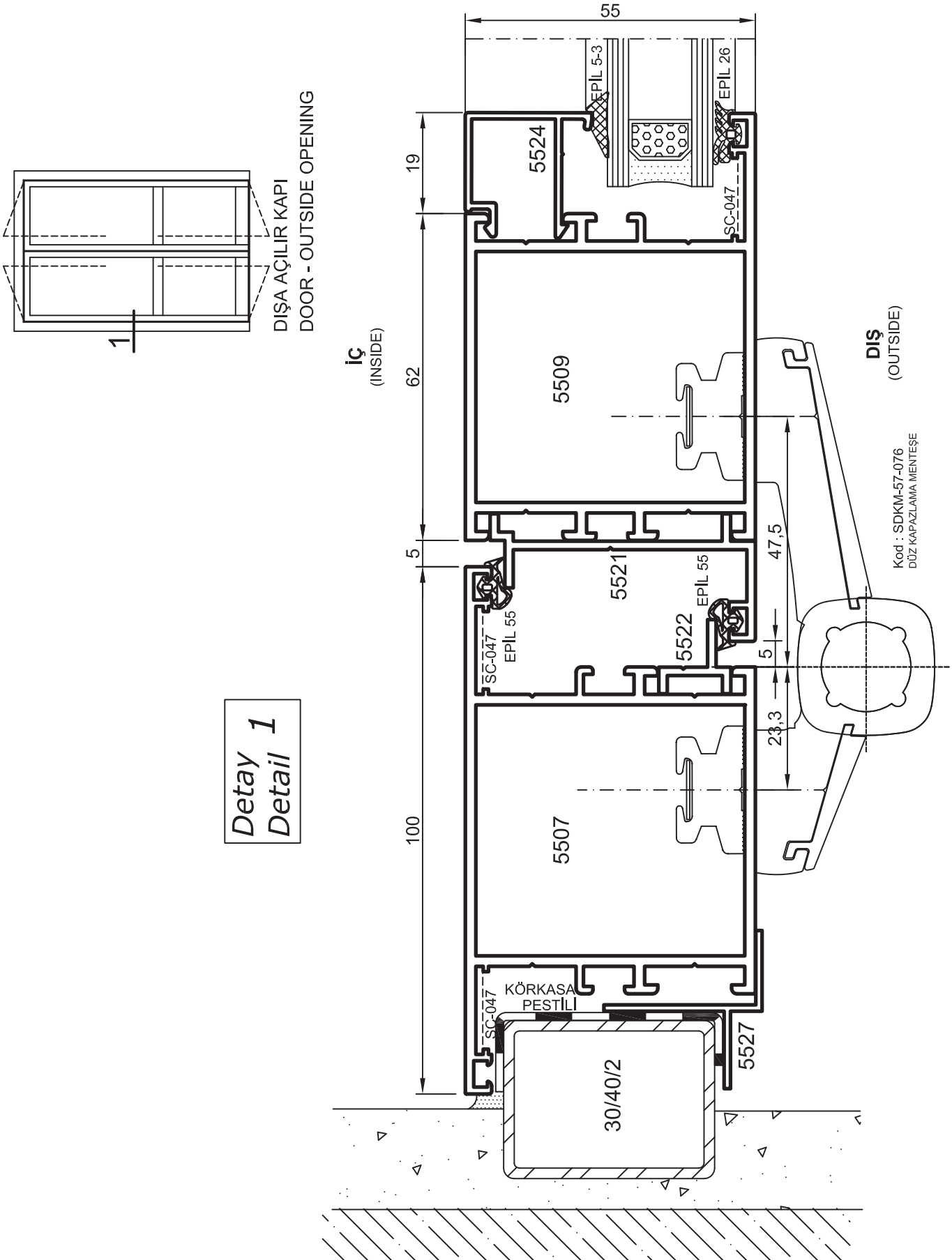

- Detaylar
- Details

Yalıtımsız Kapı-Pencere Serisi

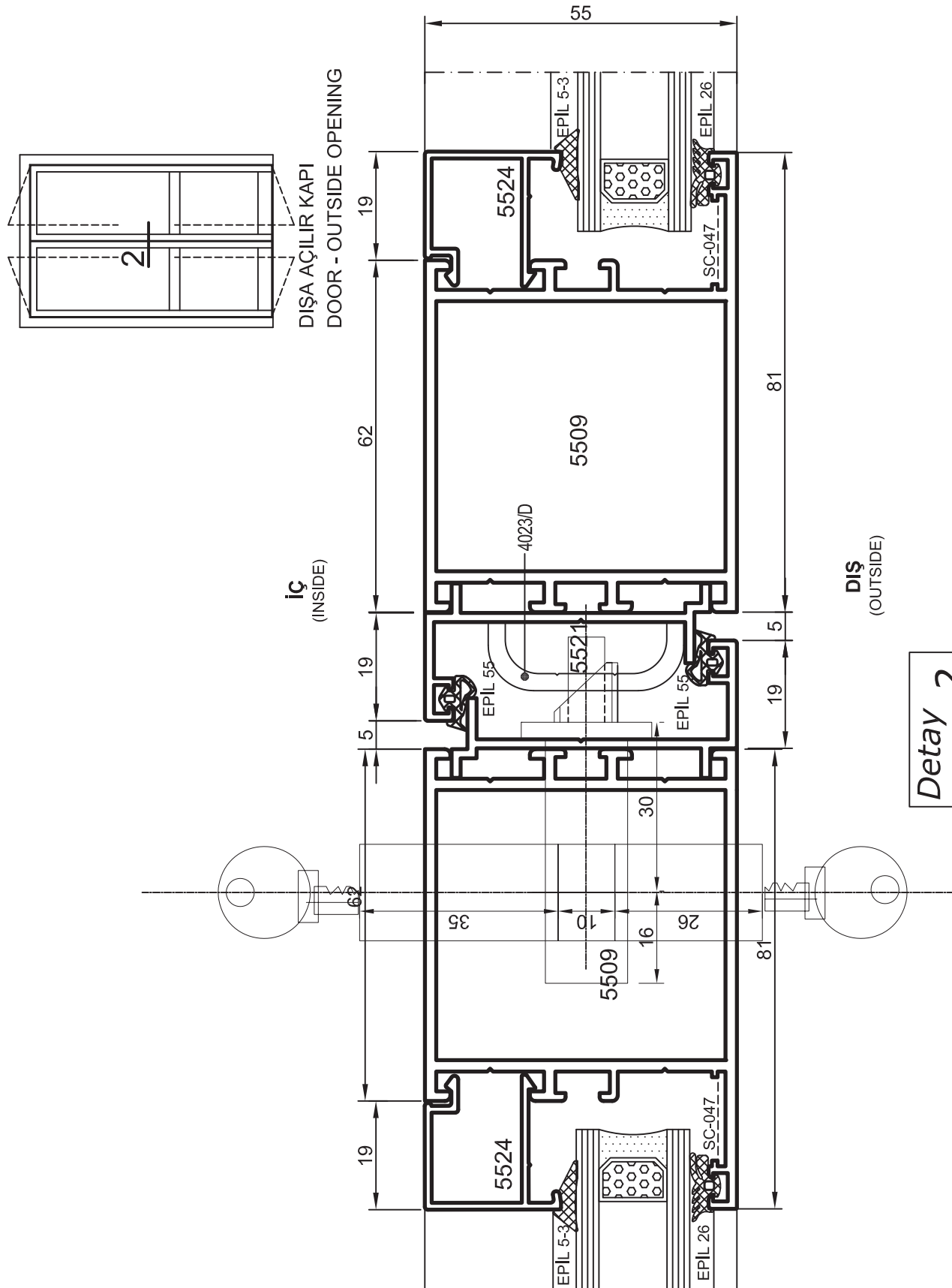

Detay 2
Detail

- Detaylar
- Details

Yalıtımsız Kapı-Pencere Serisi

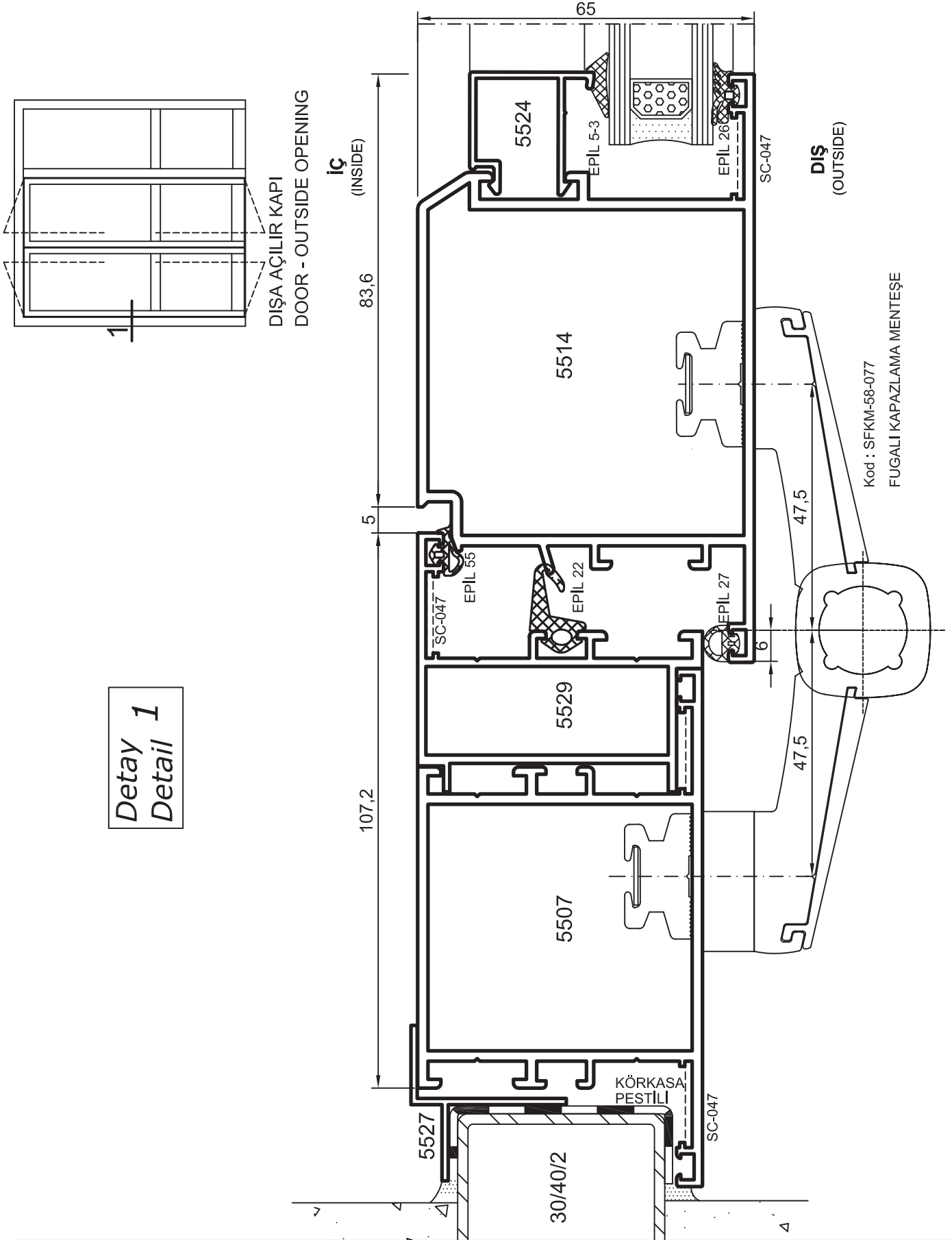

- Detaylar
- Details

Yalıtımsız Kapı-Pencere Serisi

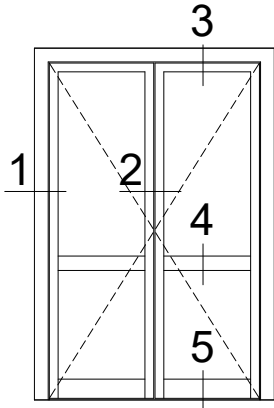

İÇE AÇILIR KAPI
DOOR - INSIDE OPENING

Kod : SFKM-55-071

FUGALI KAPAZLAMA MENTEŞE

Detay 1
Detail

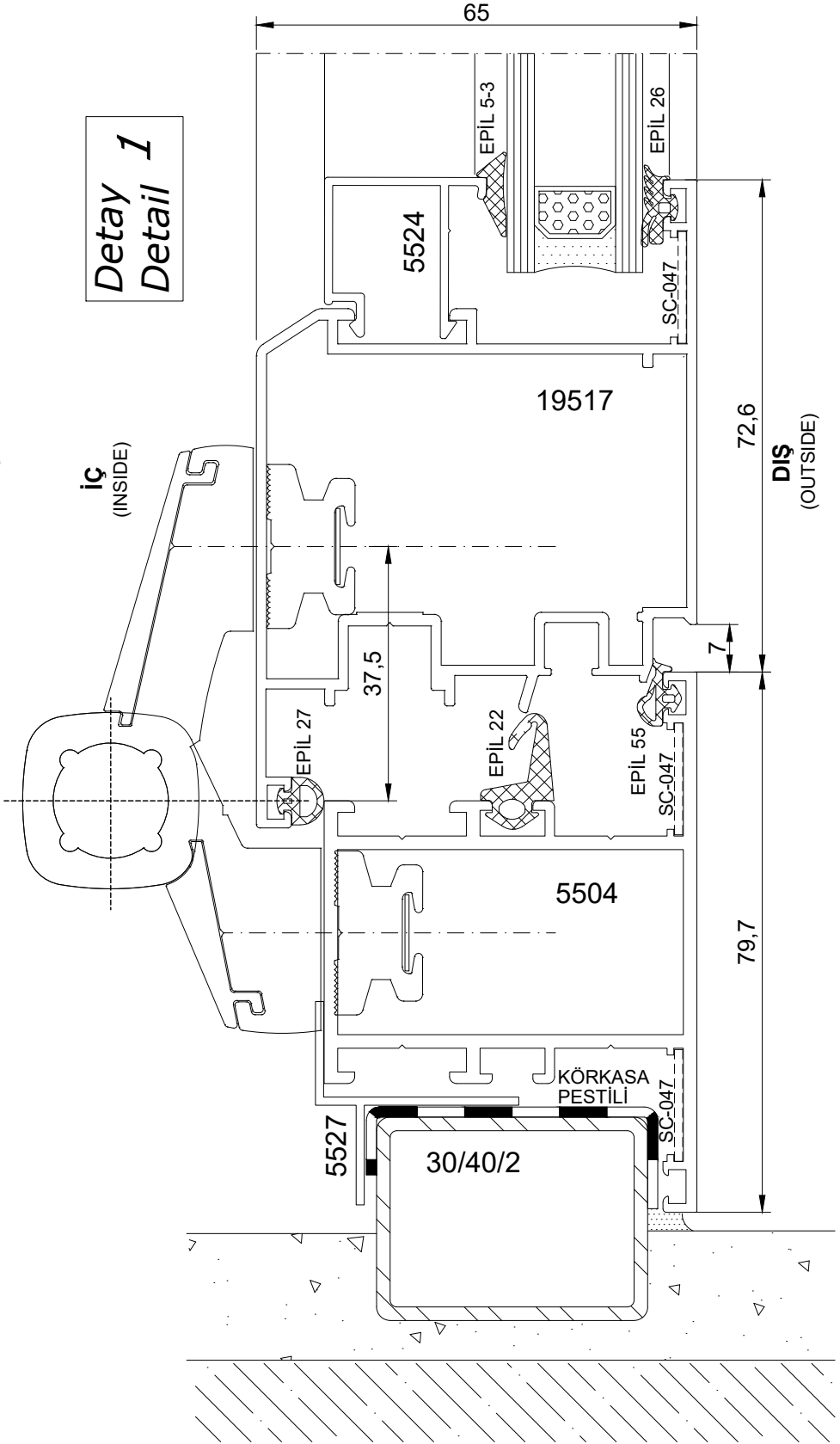

* Renk koduna göre sipariş ediniz.

- Detaylar
- Details

Yalıtımsız Kapi-Pencere Serisi

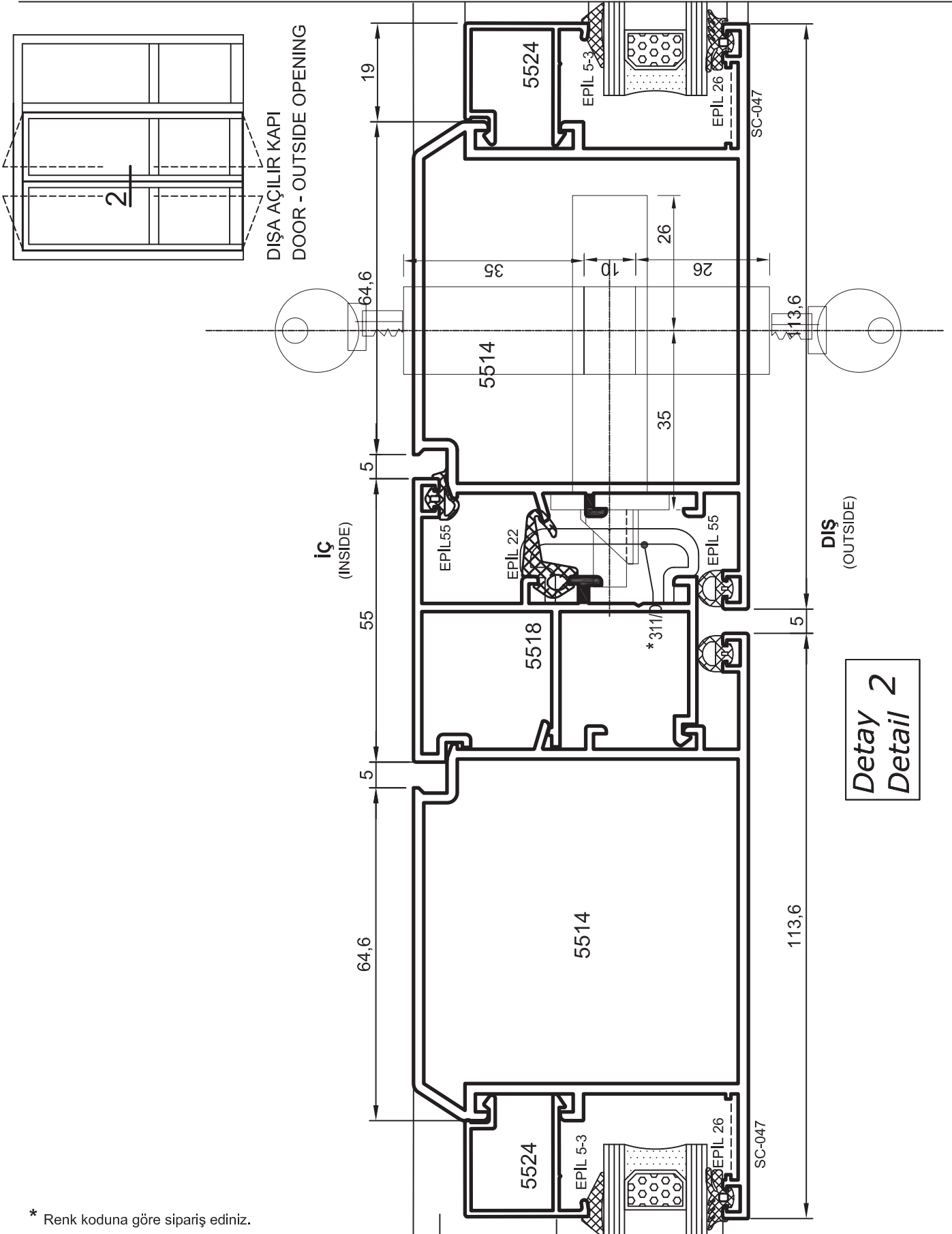

* Renk koduna göre sipariş ediniz.

- Detaylar
- Details

Yalıtımsız Kapı-Pencere Serisi

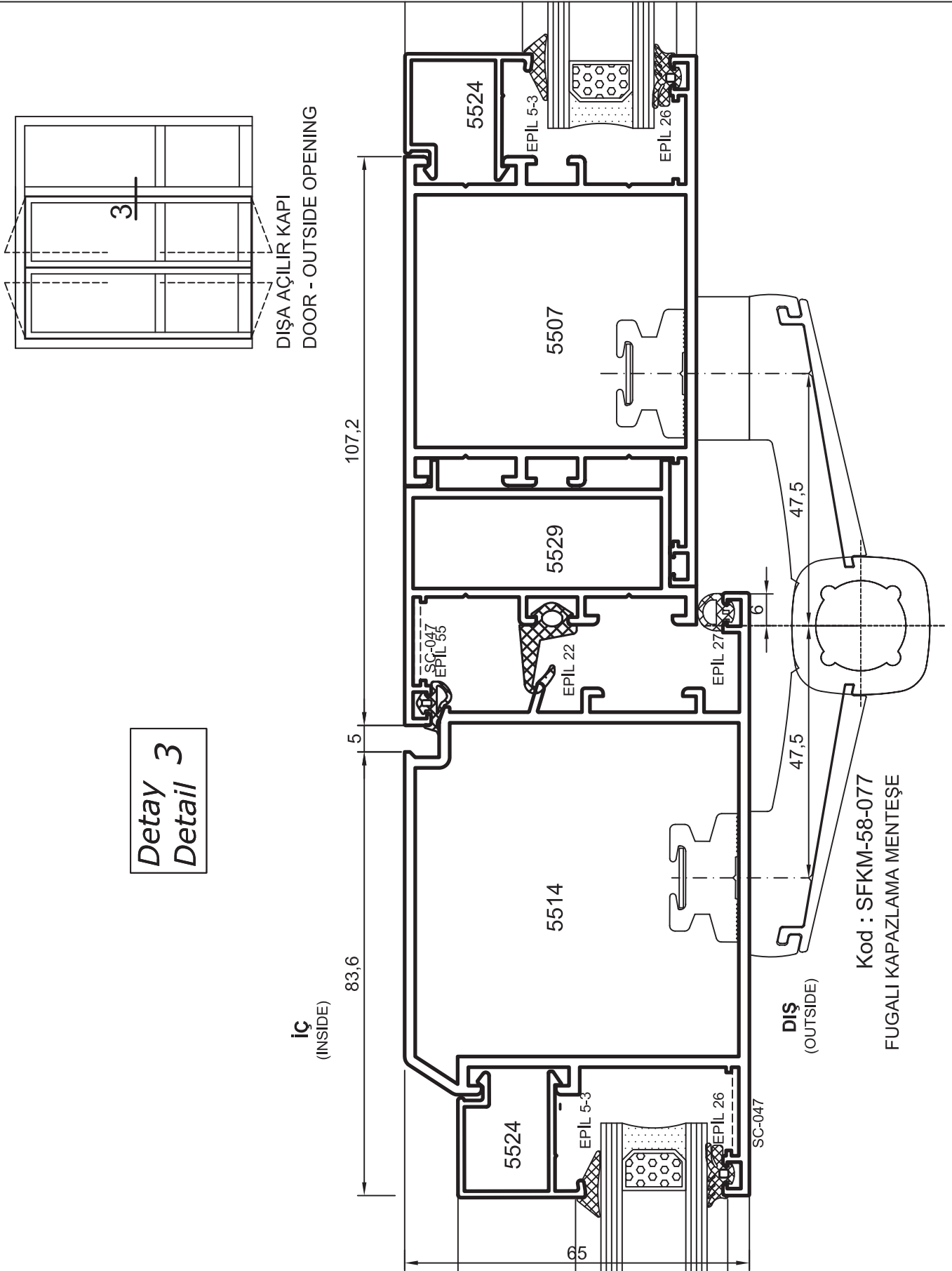

- Detaylar
- Details

Yalıtımsız Kapı-Pencere Serisi

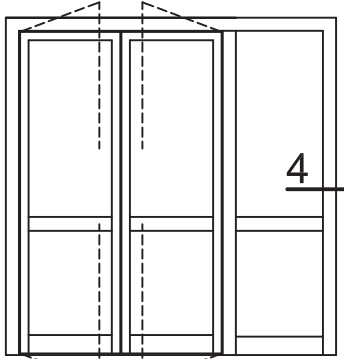

DIŞA AÇILIR KAPI
DOOR - OUTSIDE OPENING

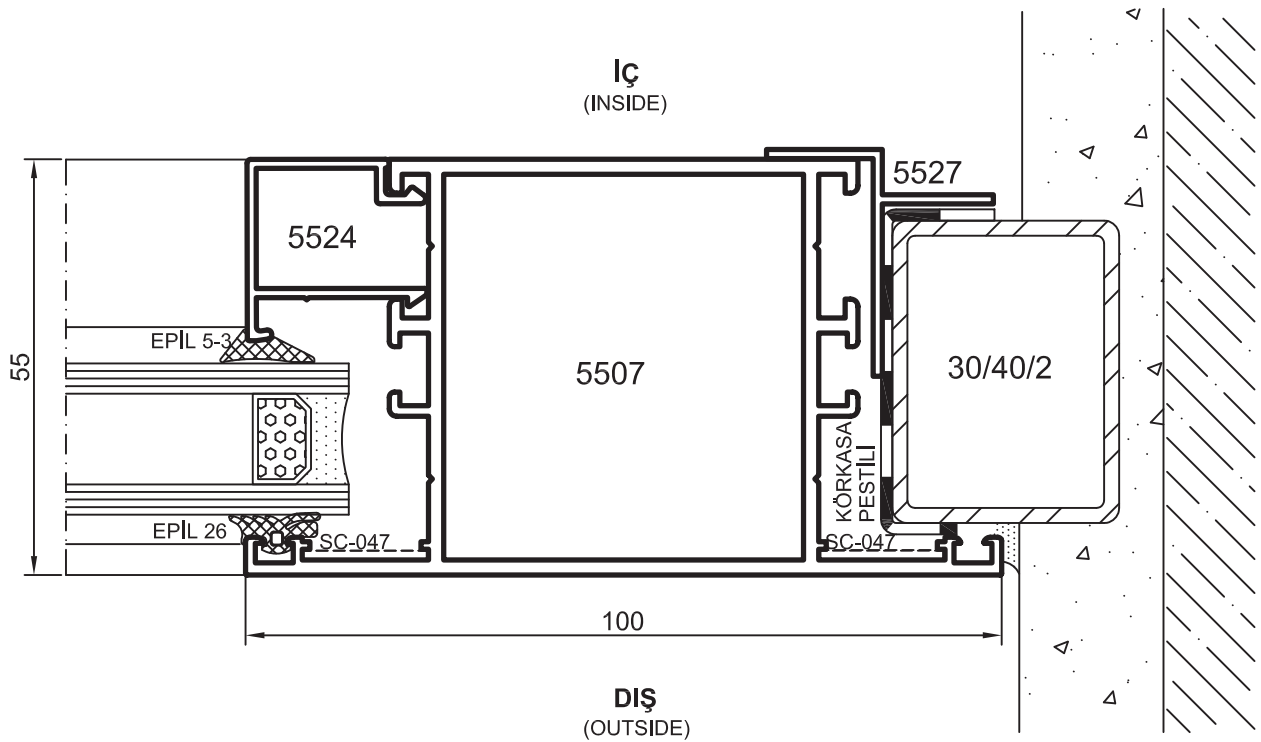

Detay 4
Detail 4

- Detaylar
- Details

Yalıtımsız Kapı-Pencere Serisi

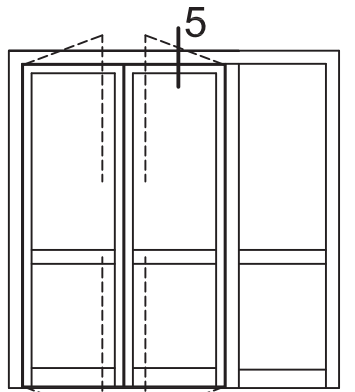

DIŞA AÇILIR KAPI
DOOR - OUTSIDE OPENING

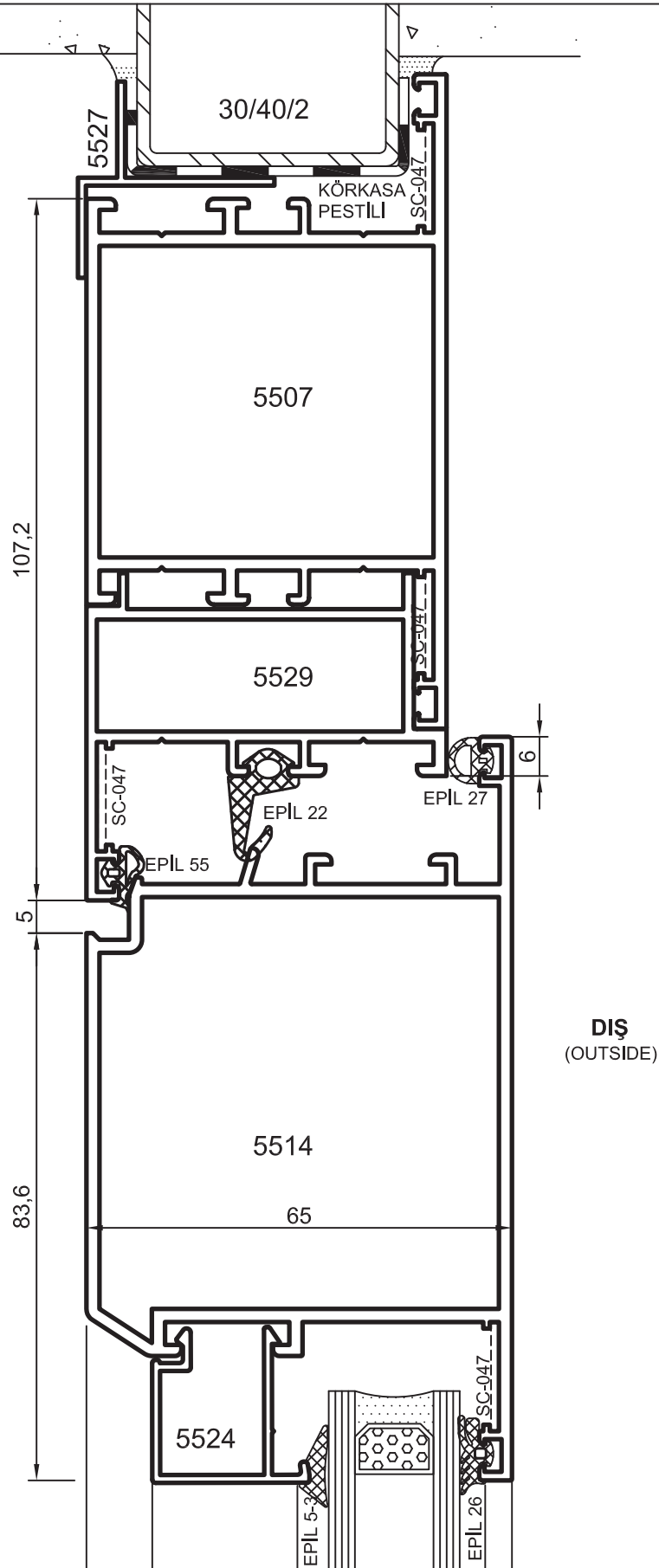

Detay
Detail 5

- Detaylar
- Details

Yalıtımsız Kapi-Pencere Serisi

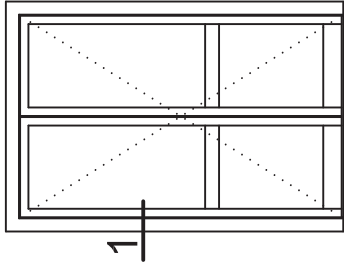

ÇARPMA KAPI
SWING DOOR

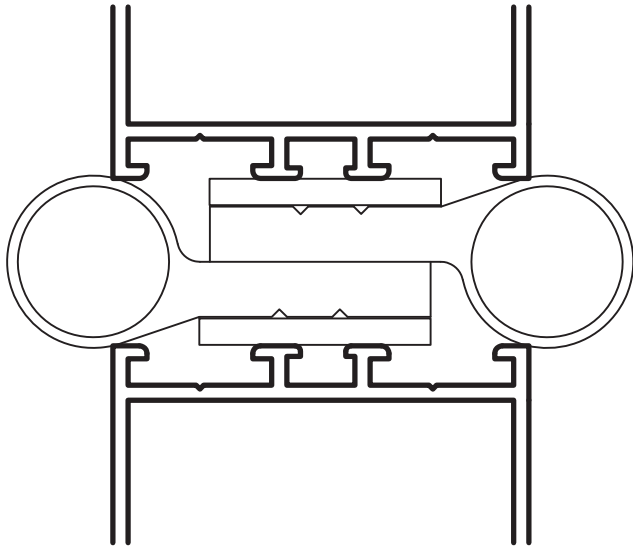

İÇ
(INSIDE)

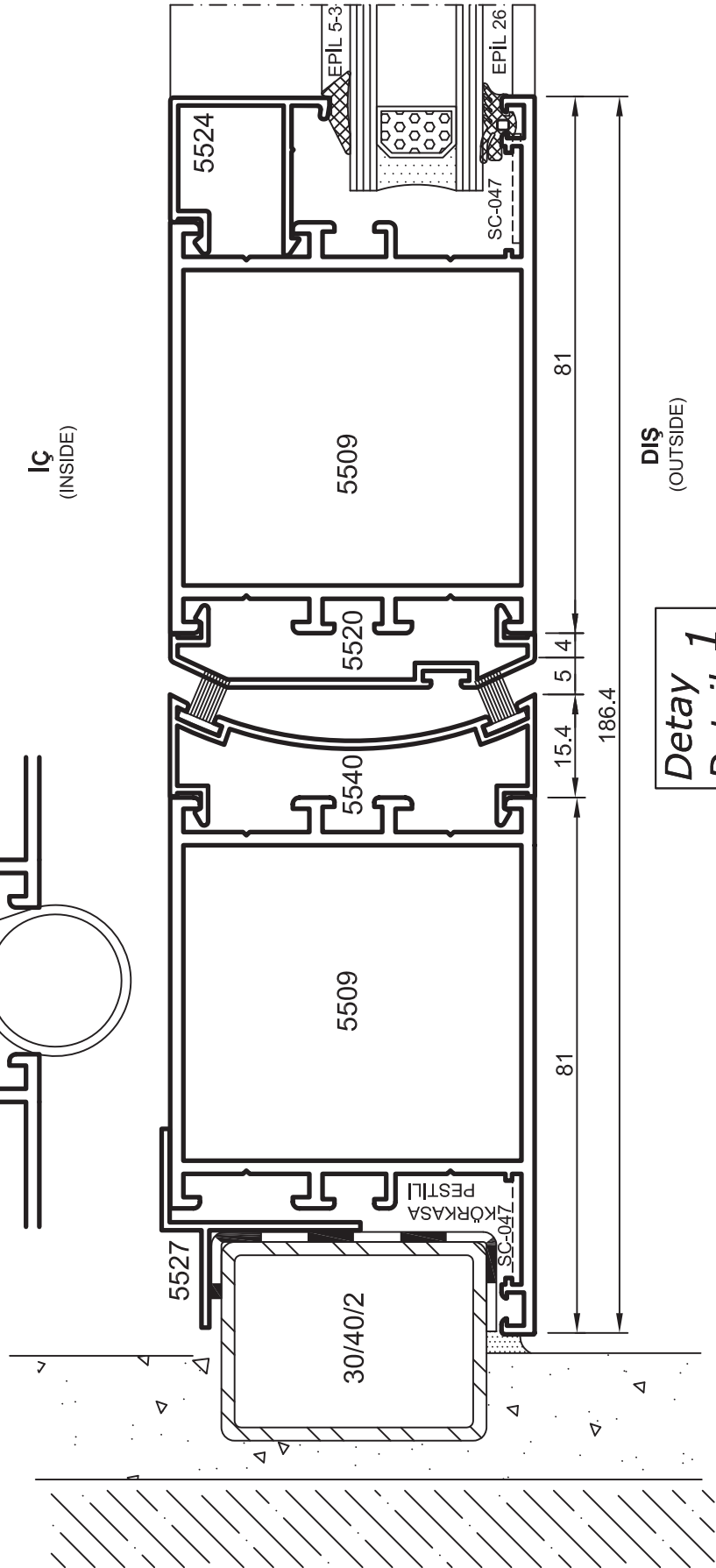

- Detaylar
- Details

Yalıtımsız Kapı-Pencere Serisi

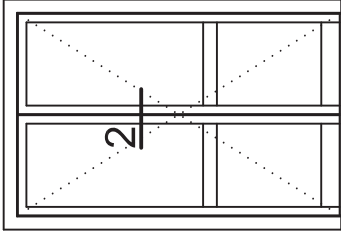

ÇARPMA KAPI
SWING DOOR

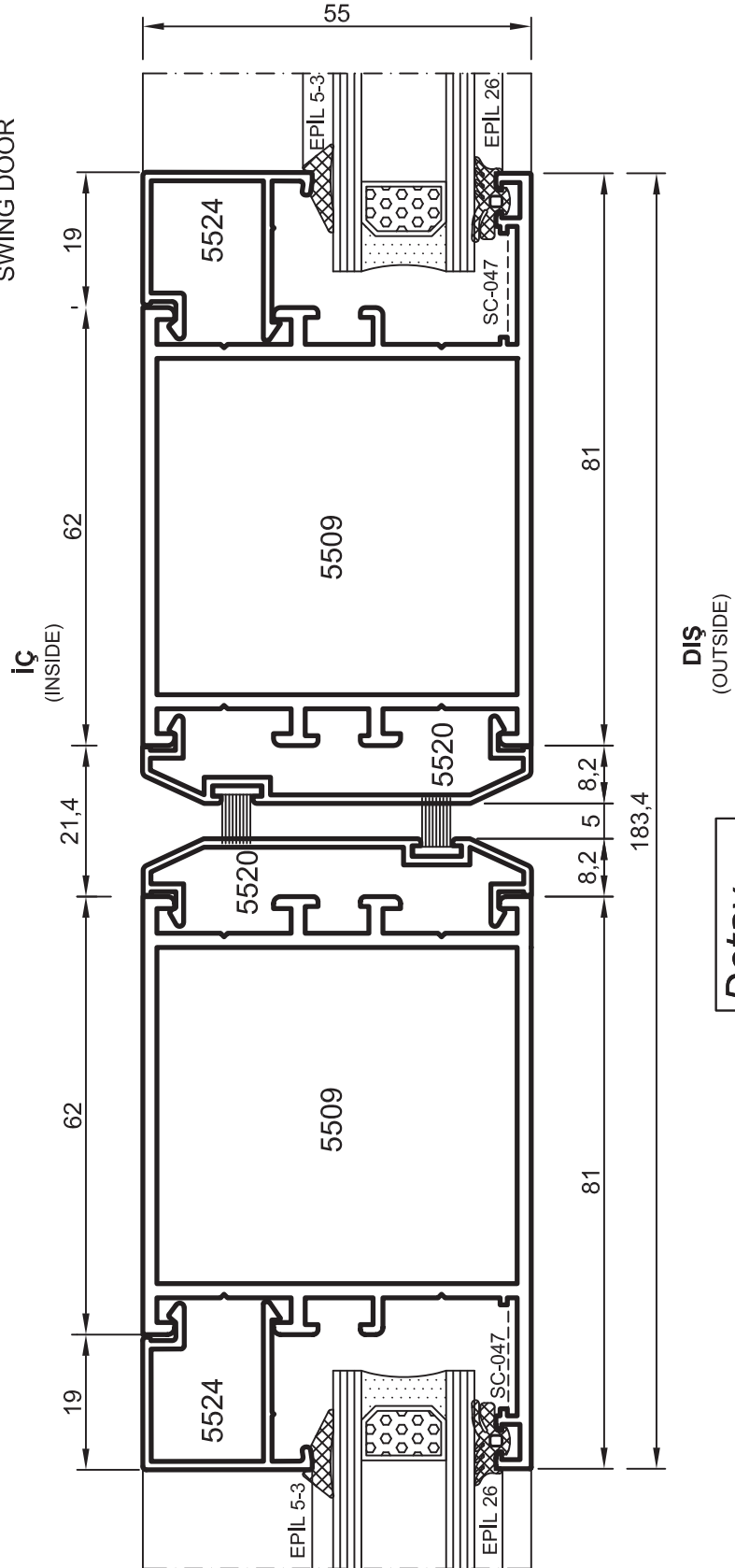

Detay 2
Detail

- Detaylar
- Details

Yalıtımsız Kapı-Pencere Serisi

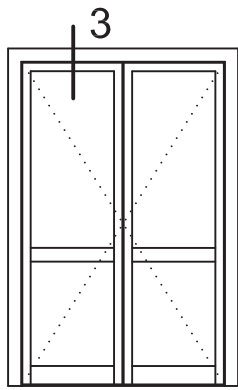

ÇARPMA KAPI
SWING DOOR

Detay
Detail 3

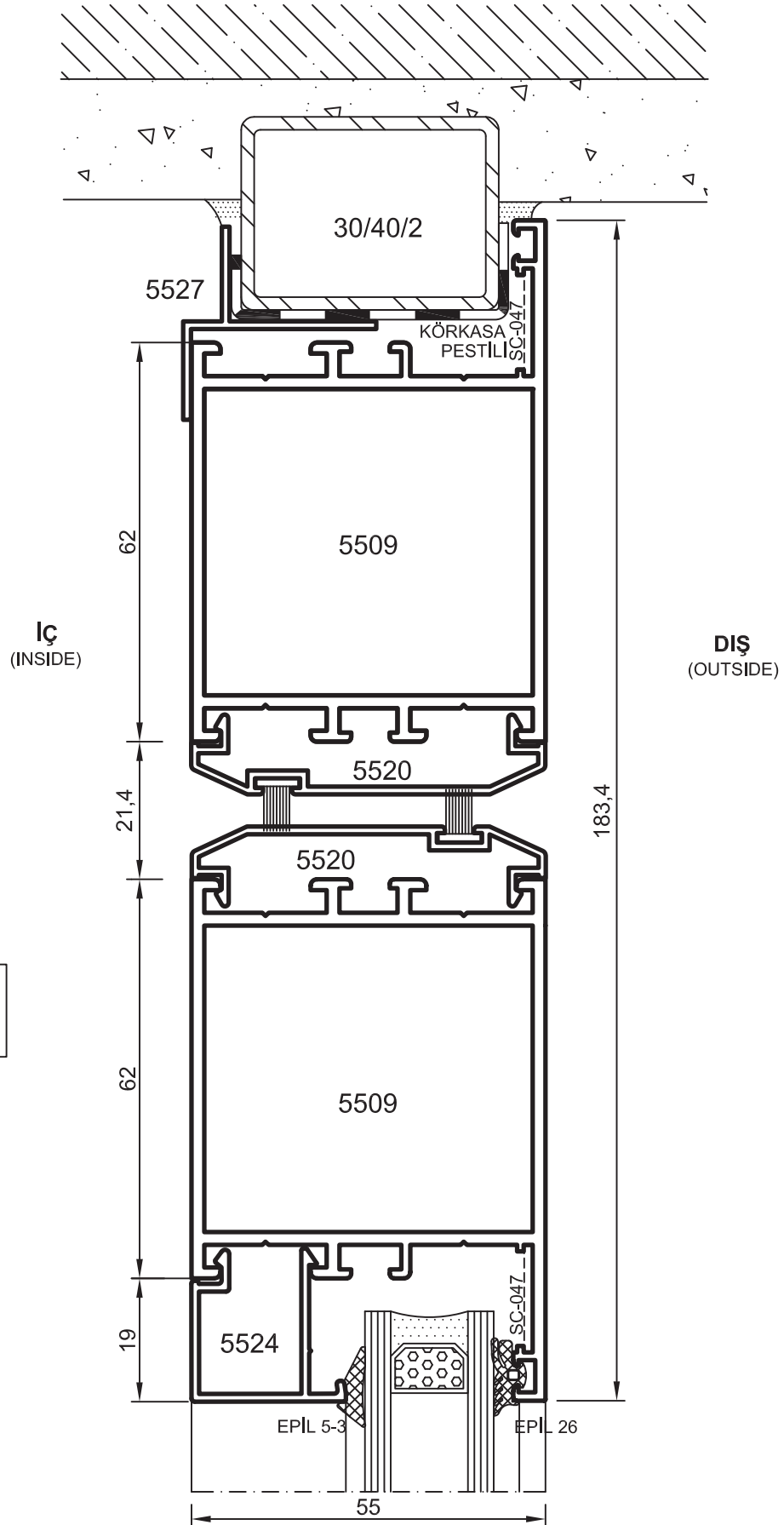

- Detaylar
- Details

Yalıtımsız Kapı-Pencere Serisi

KATLANIR KAPI UYGULAMA TİPLERİ / Folding Sliding System Types

TİP 321

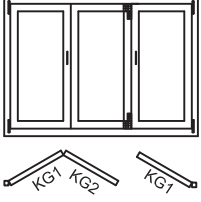

TİP 330

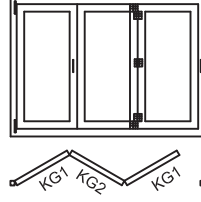

TİP 431

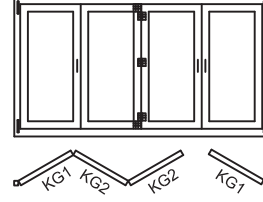

TİP 541

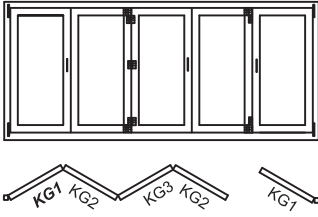

TİP 550

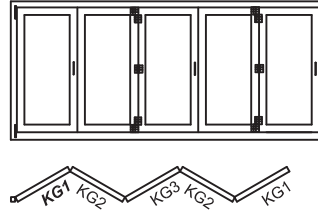

TİP 532

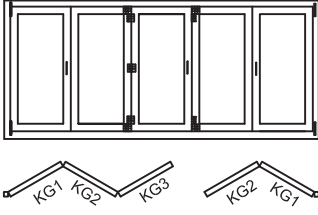

TİP 651

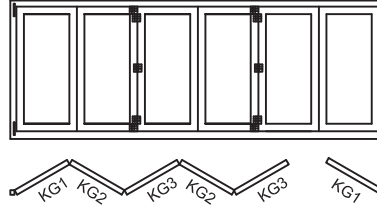

TİP 633

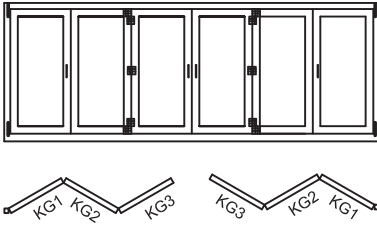

TİP 761

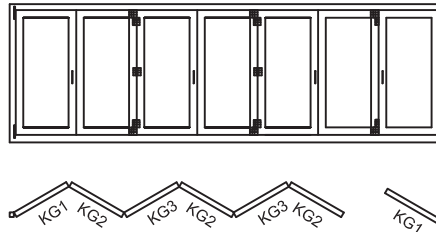

TİP 770

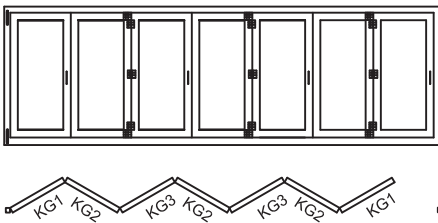

TİP 743

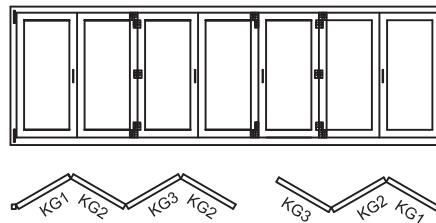

KANAT GENİŞLİĞİ(KG): Min 600mm-Maks 900mm

KANAT YÜKSEKLİĞİ(KY):Min 850mm-Maks 2400mm

KANAT AĞIRLIĞI: MAX 80 kg

- Detaylar
- Details

Yalıtımsız Kapi-Pencere Serisi

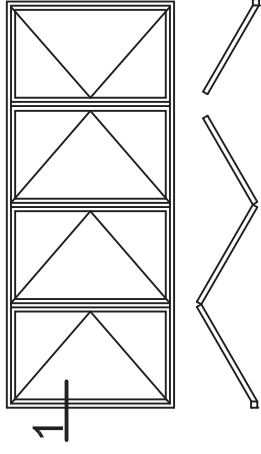

KATLANIR SÜRME KAPI
Folding Sliding System Detail

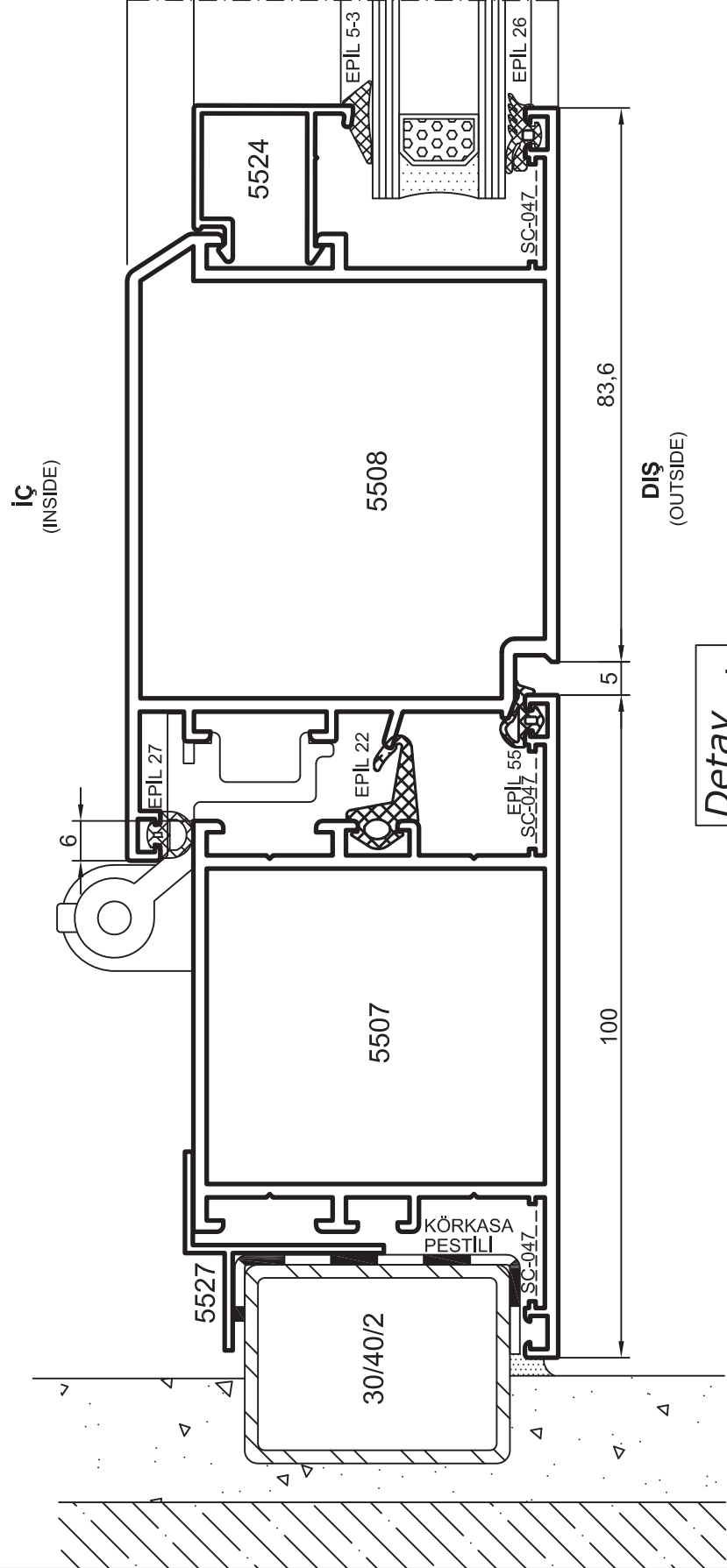

Detay 1
Detail 1

- Detaylar
- Details

Yalıtımsız Kapi-Pencere Serisi

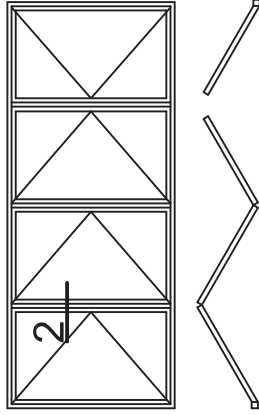

KATLANIR SÜRME KAPI
Folding Sliding System Detail

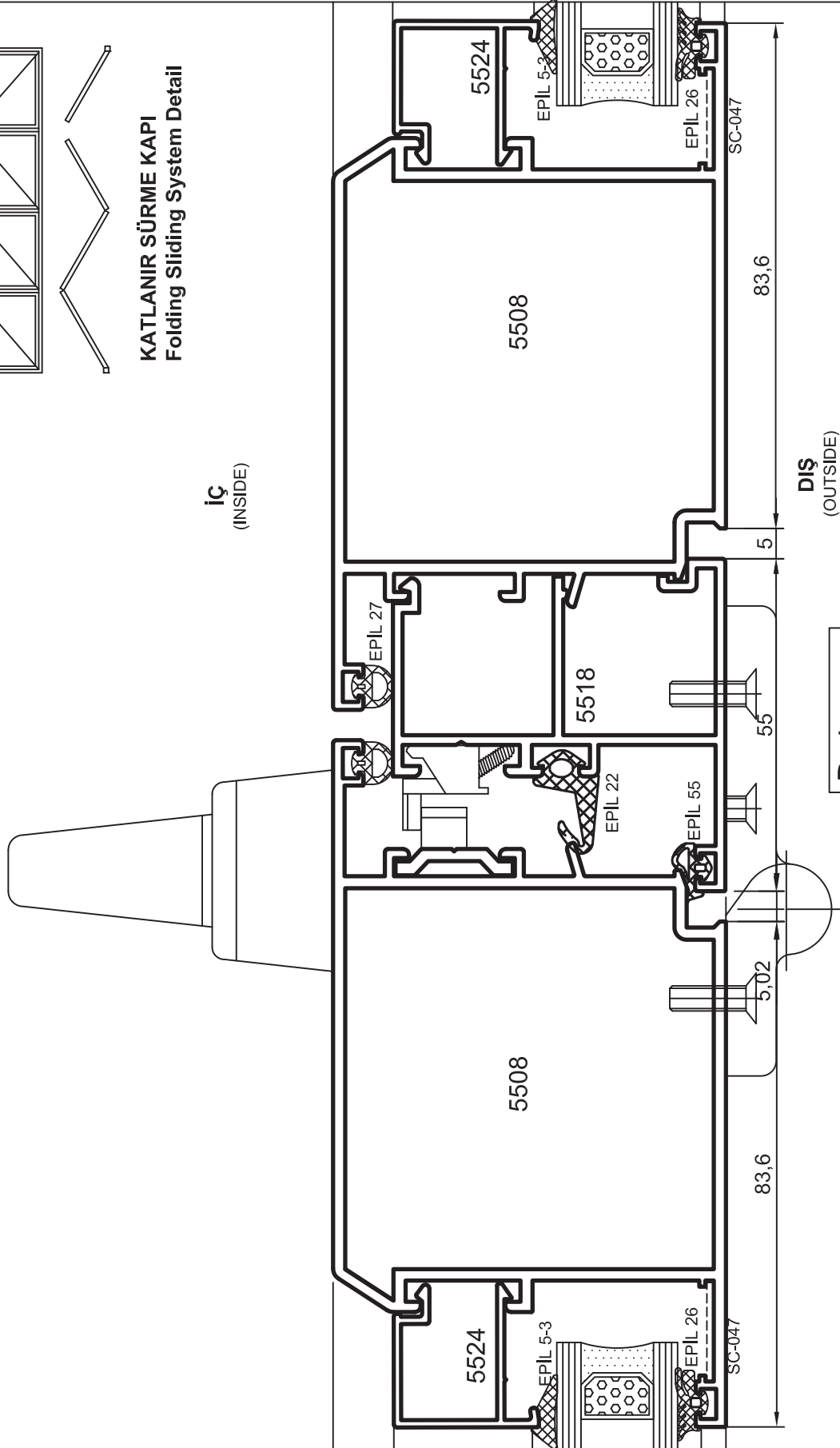

Detay 2
Detail

- Detaylar
- Details

Yalıtımsız Kapi-Pencere Serisi

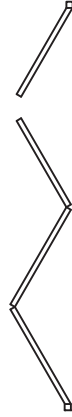
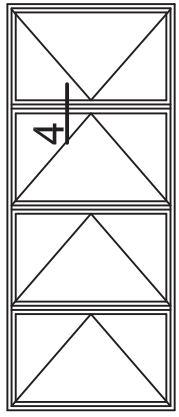

KATLANIR SÜRME KAPI
Folding Sliding System Detail

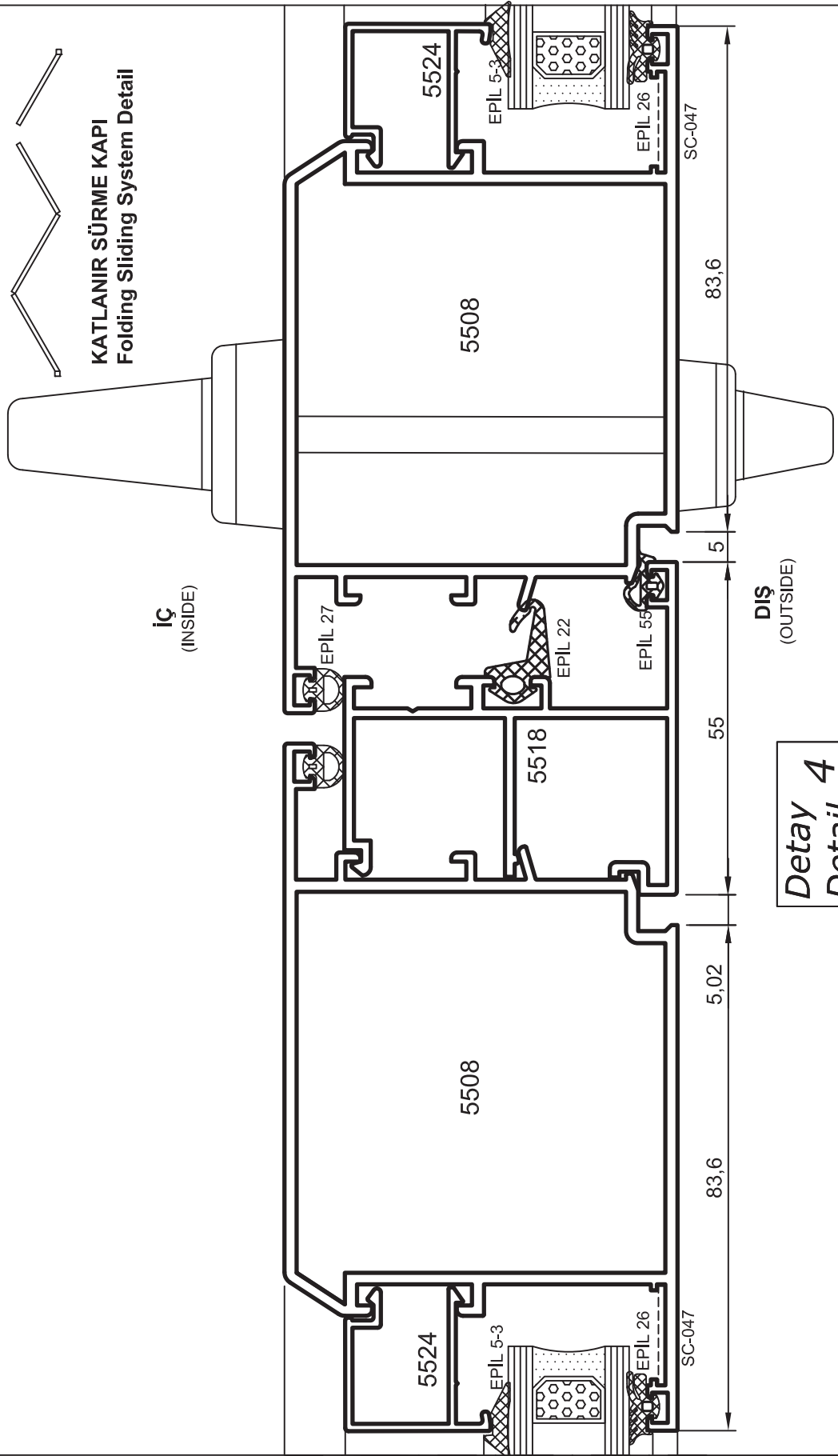

Detay 4
Detail

- Detaylar
- Details

Yalıtımsız Kapi-Pencere Serisi

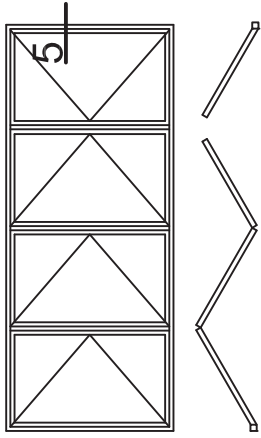

KATLANIR SÜRME KAPI
Folding Sliding System Detail

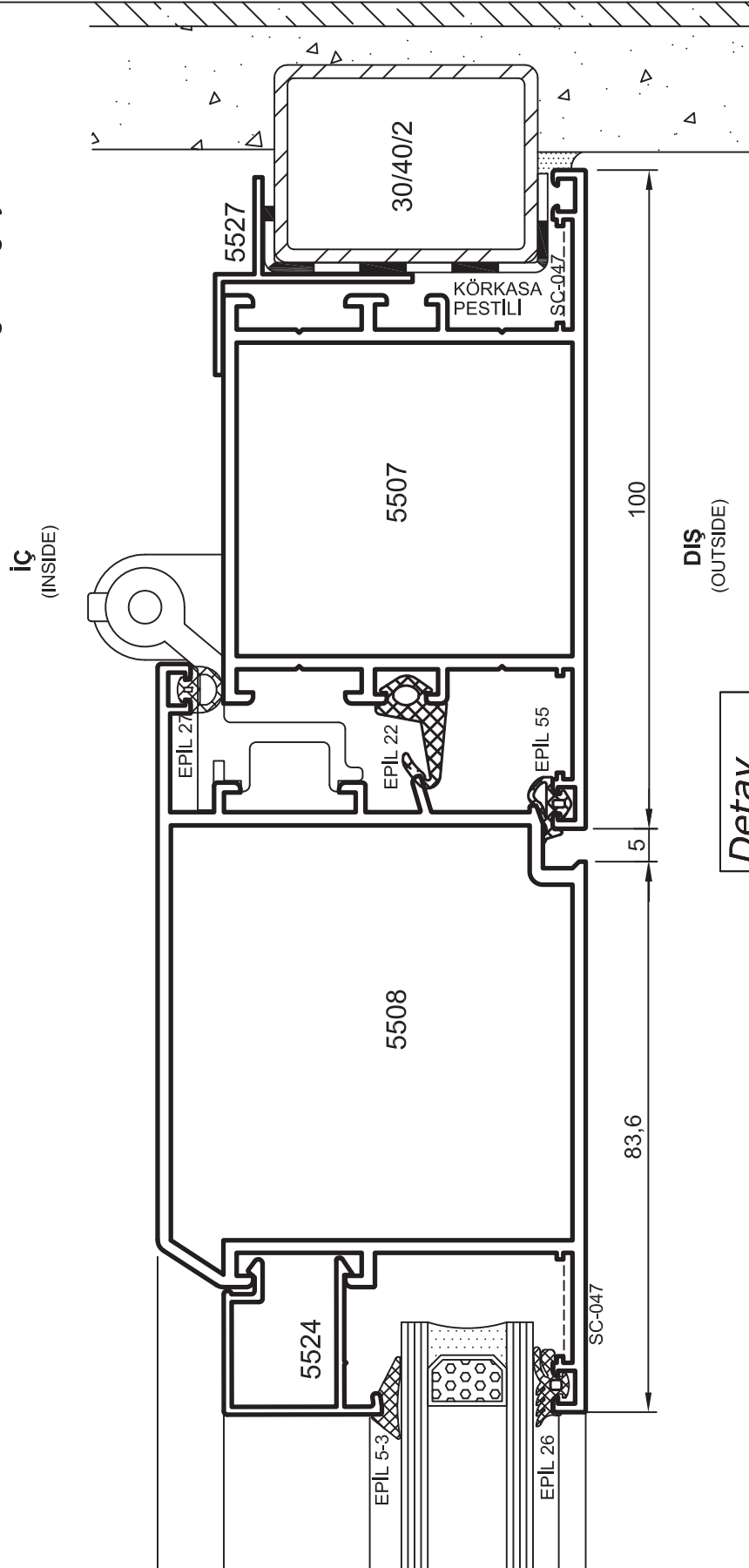

Detay 5
Detail

- Detaylar
- Details

Yalıtımsız Kapı-Pencere Serisi

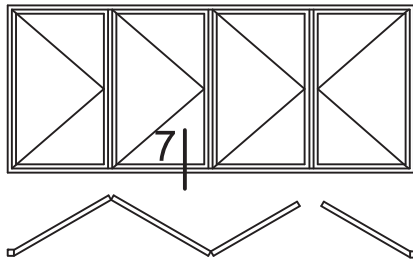

KATLANIR SÜRME KAPI
Folding Sliding System Detail

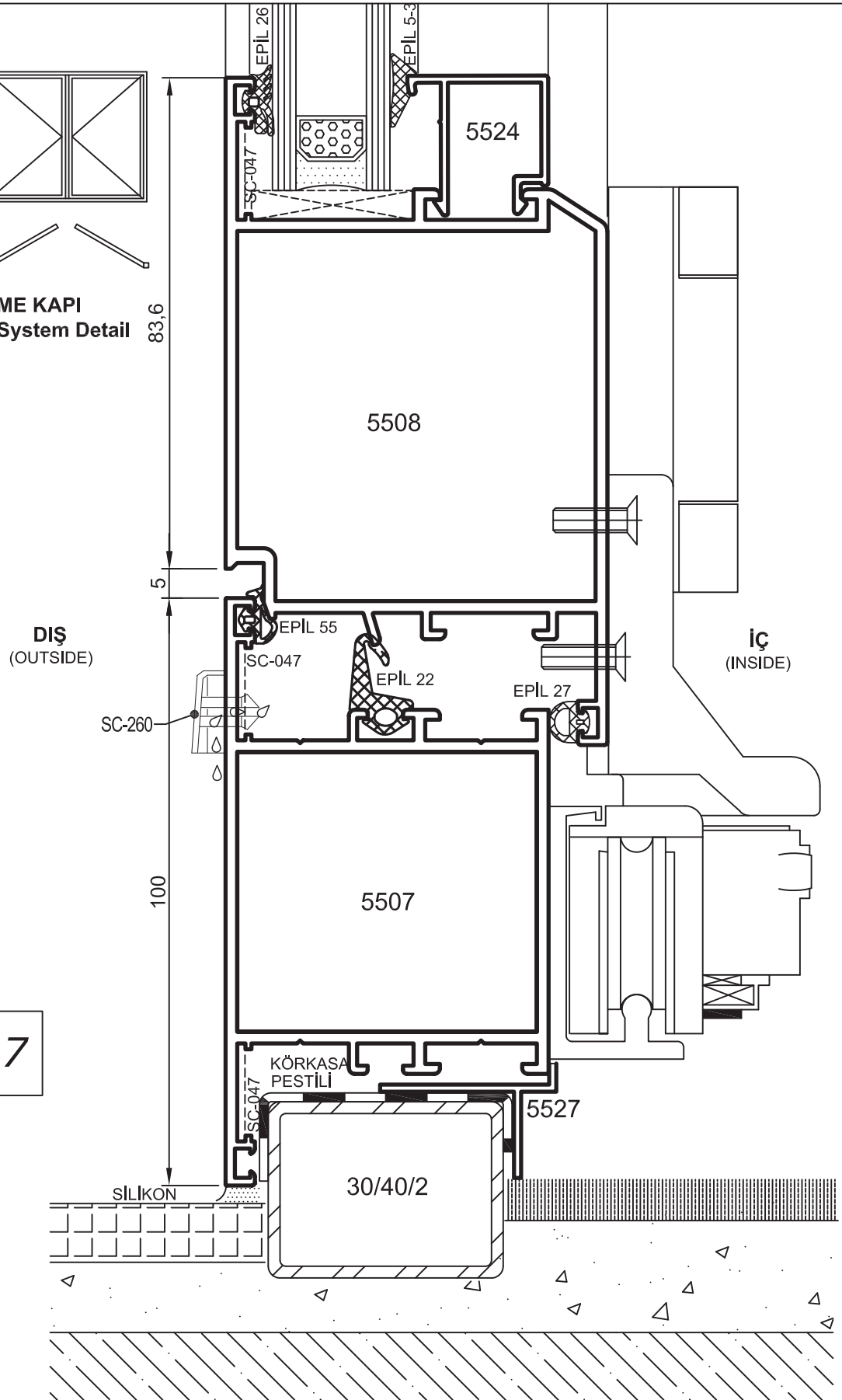

Detay
Detail 7

- Detaylar
- Details

Yalıtımsız Kapı-Pencere Serisi

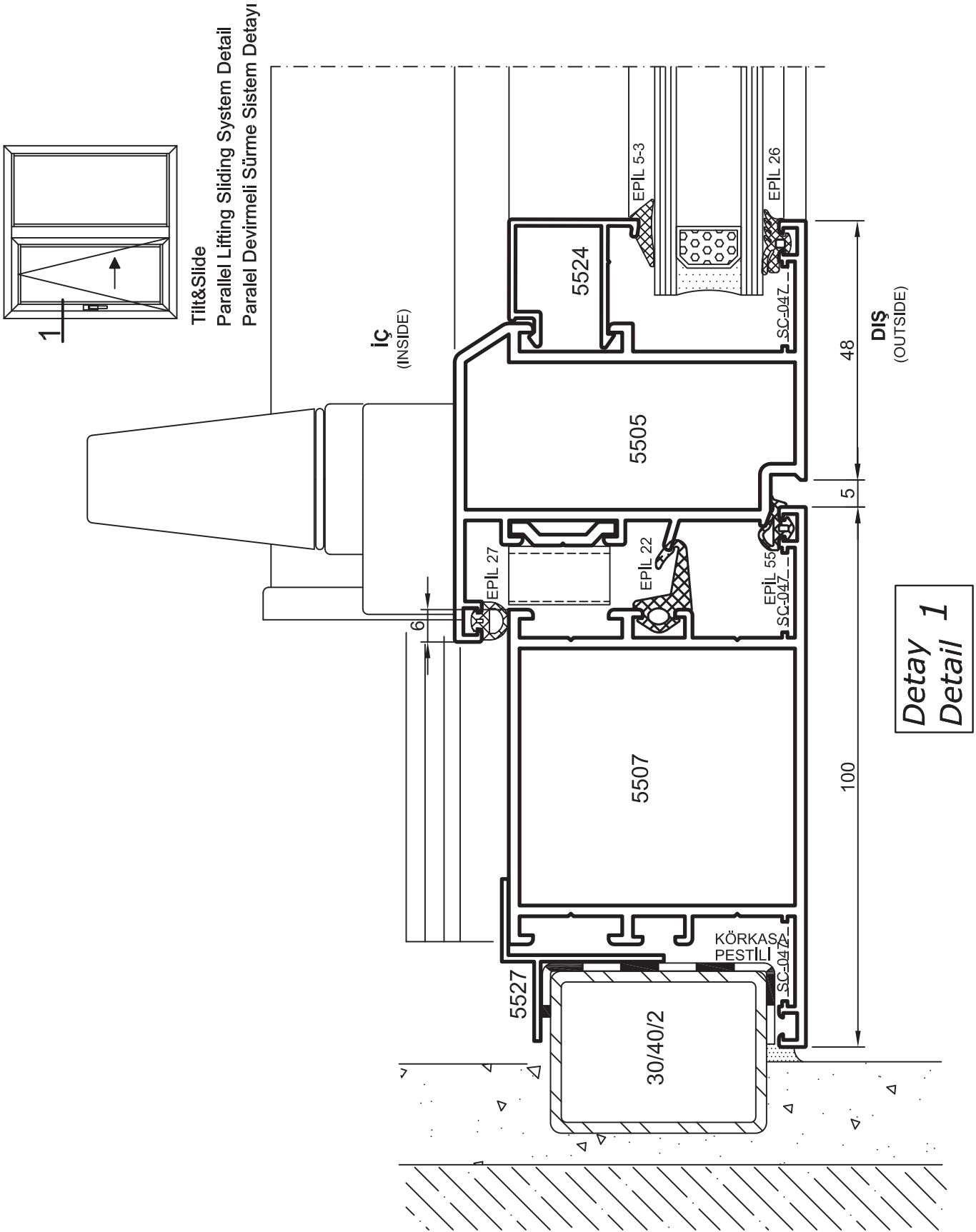

- Detaylar
- Details

Yalıtımsız Kapi-Pencere Serisi

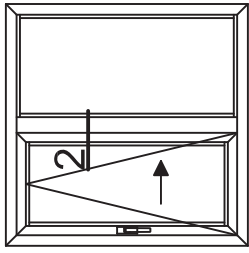

Tilt&Slide
Parallel Lifting Sliding System Detail
Paralel Devirmeli Sürme Sistem Detayı

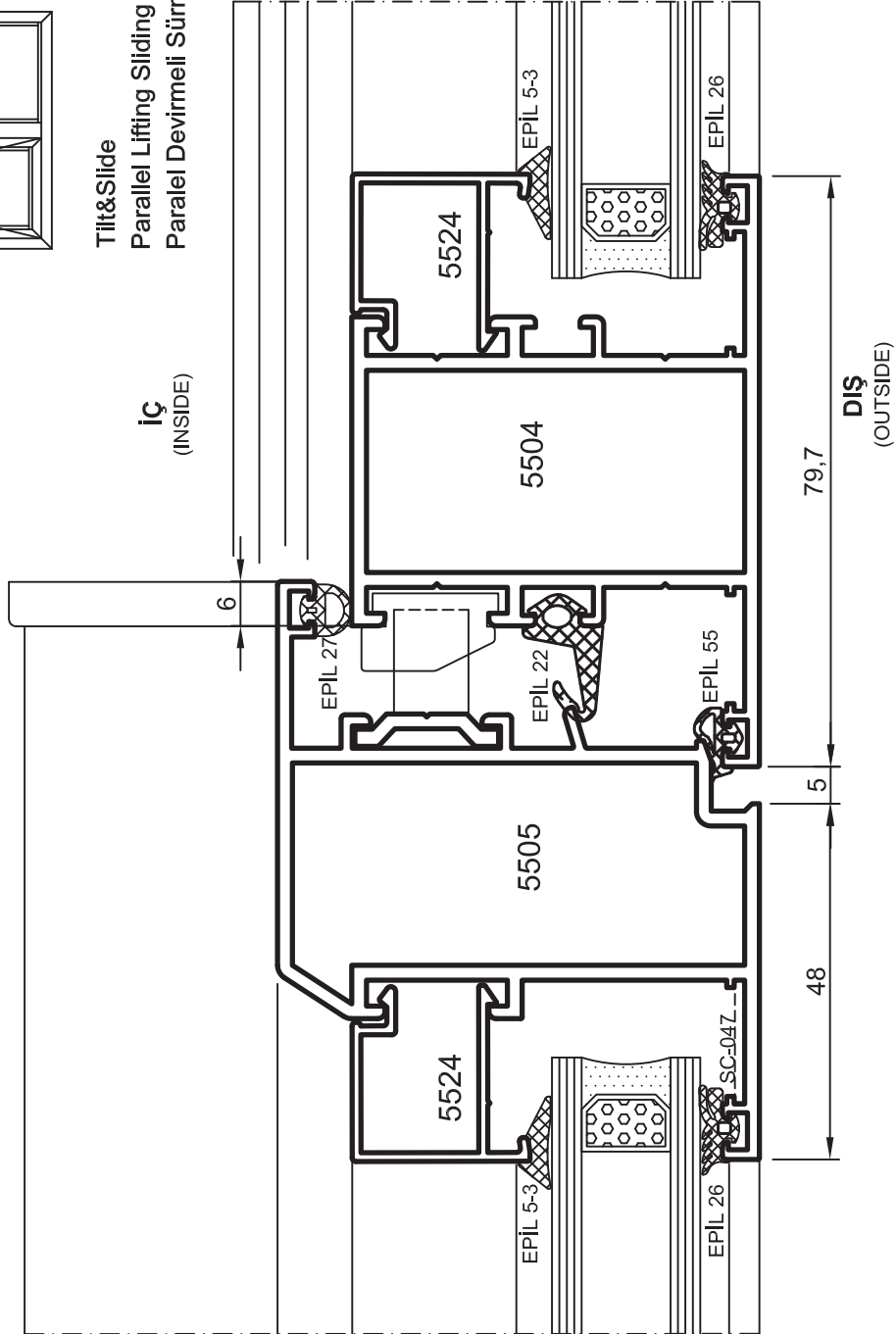

Detay 2
Detail

- Detaylar
- Details

Yalıtımsız Kapı-Pencere Serisi

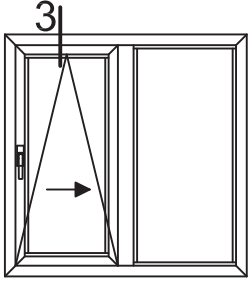

Tilt&Slide
Parallel Lifting Sliding System Detail
Paralel Devirmeli Sürme Sistem Detayı

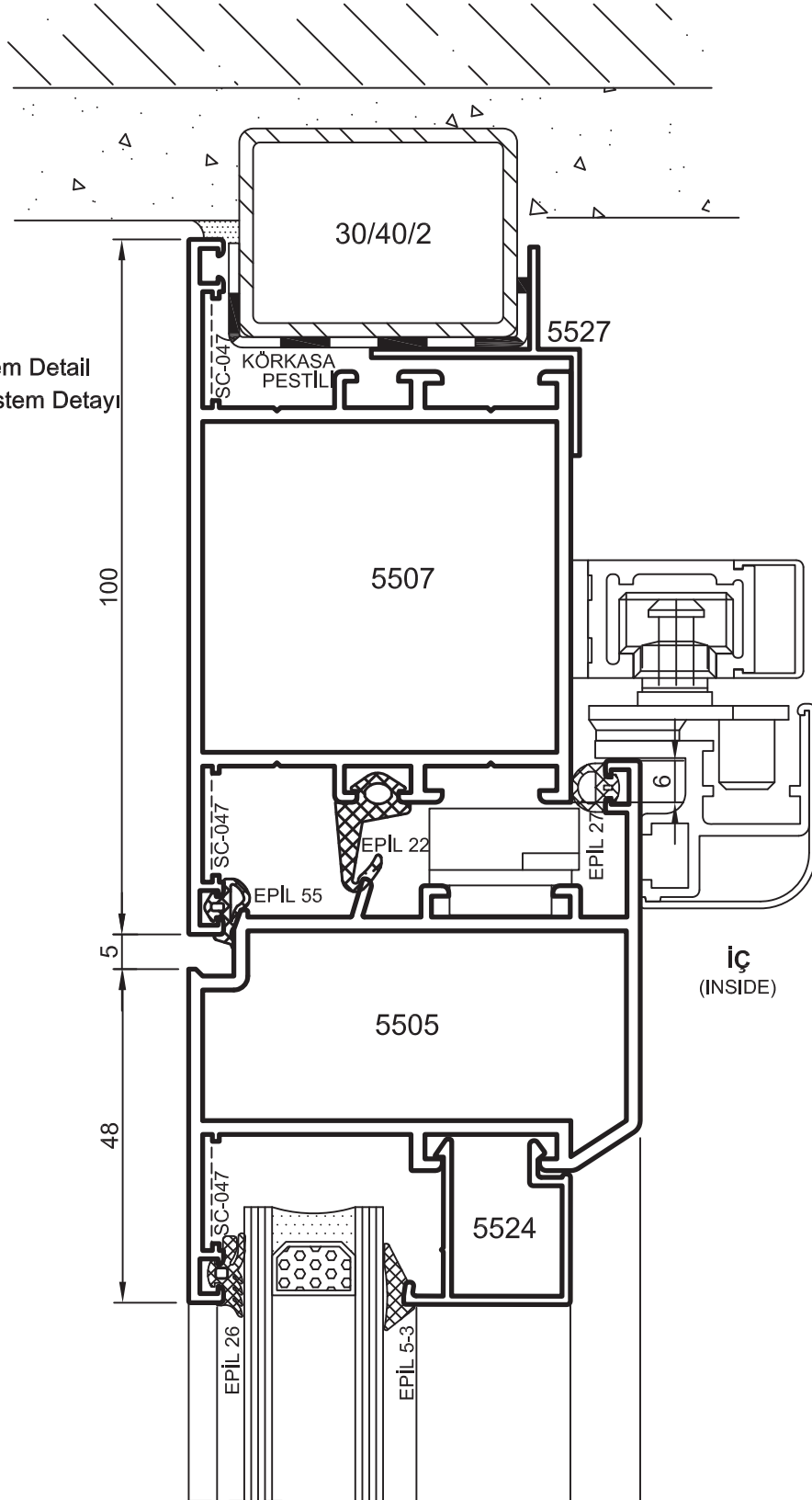

Detay
Detail 3

- Detaylar
- Details

Yalıtımsız Kapı-Pencere Serisi

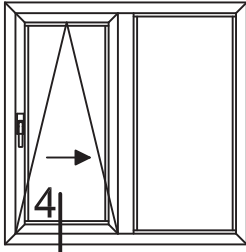

Tilt&Slide
Parallel Lifting Sliding System Detail
Paralel Devirmeli Sürme Sistem Detayı

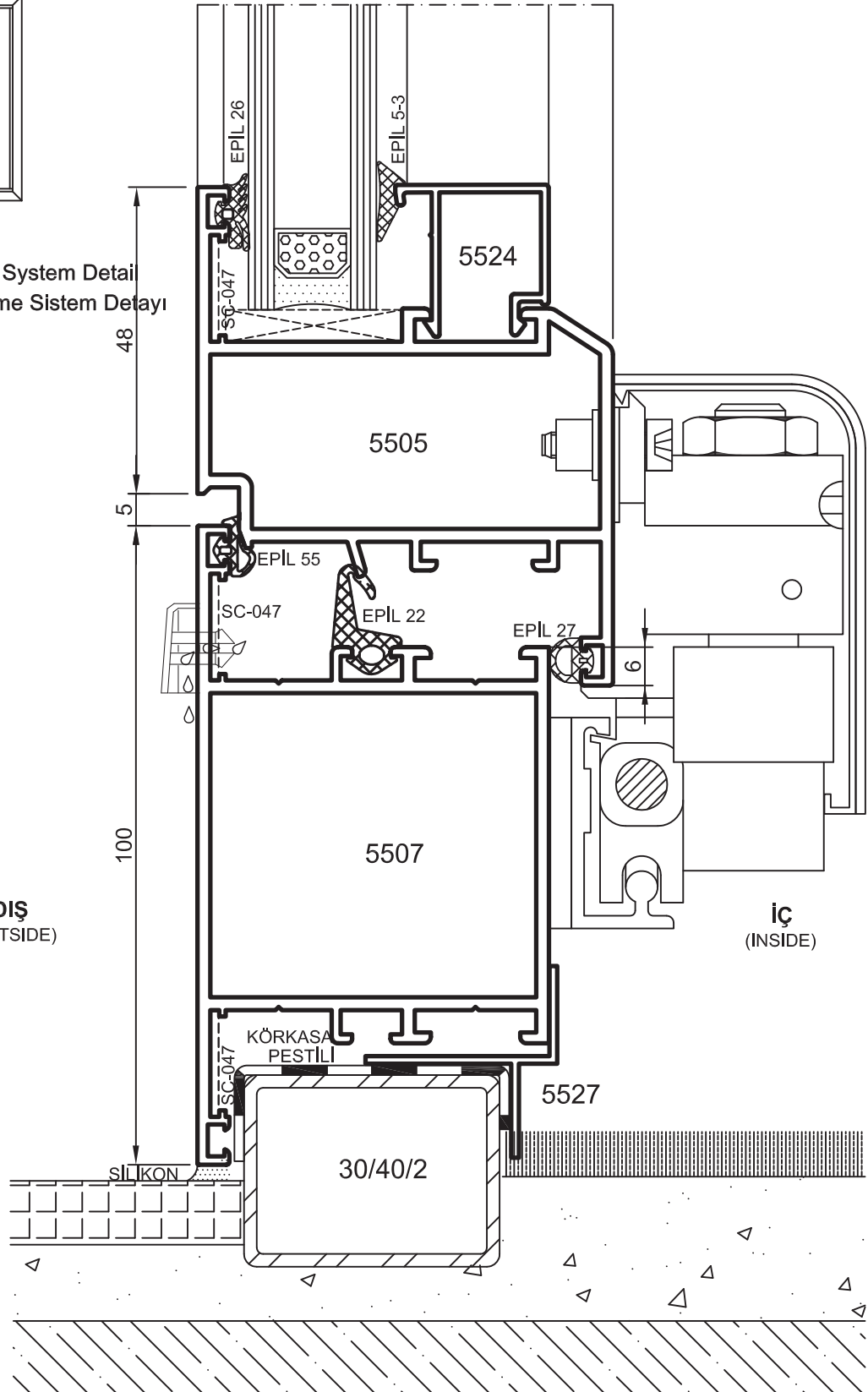

Detay
Detail 4

S55
WINDOWS and DOORS
SYSTEM
FABRICATION and CUTTING

S55
KAPI ve PENCERE SİSTEMİ
ÜRETİM İŞLEMLERİ

- Montaj Çizimleri
- Assembly Drawings

Yalıtımsız Kapı-Pencere Serisi

PRES BAĞLANTI DETAYI

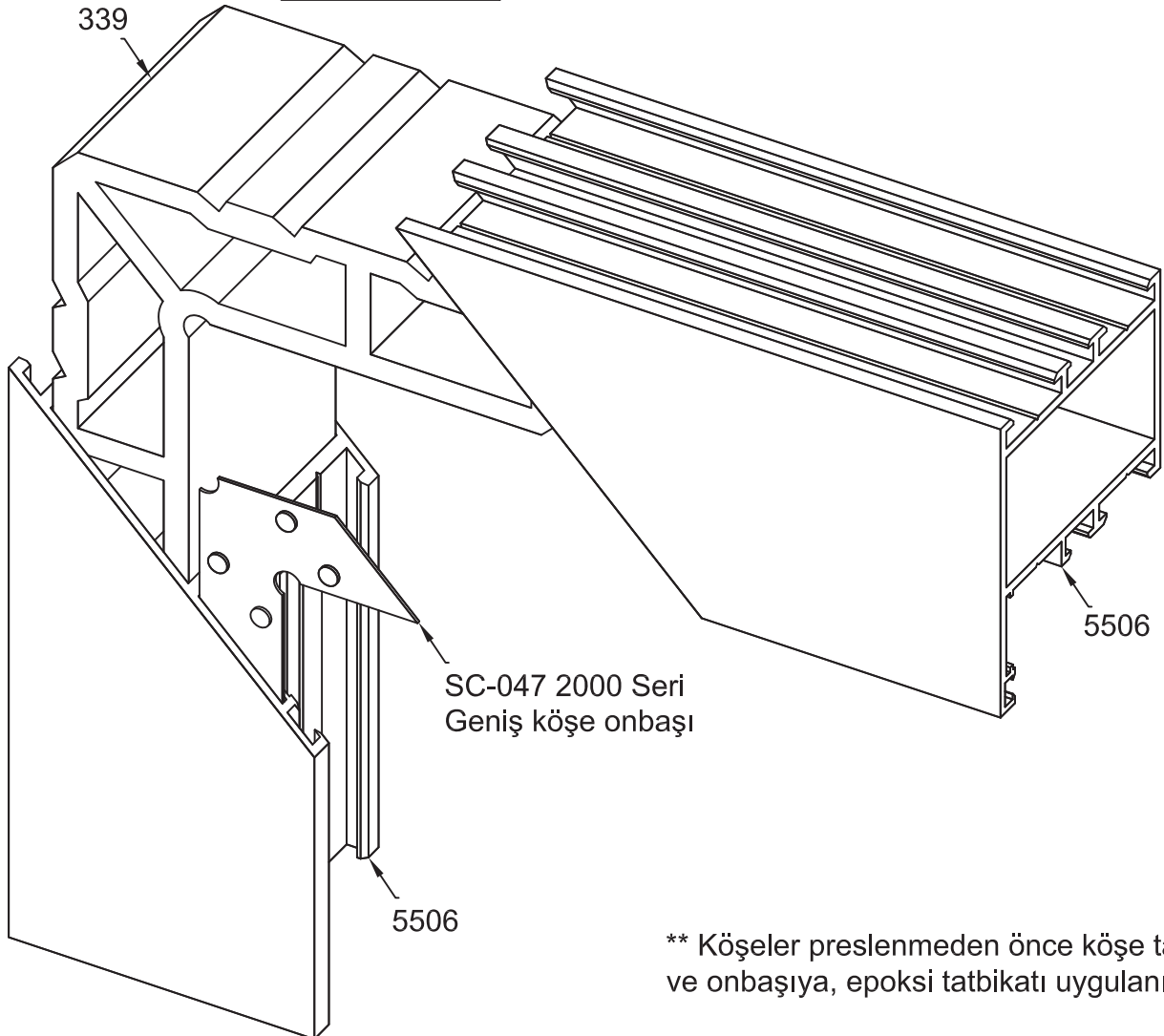
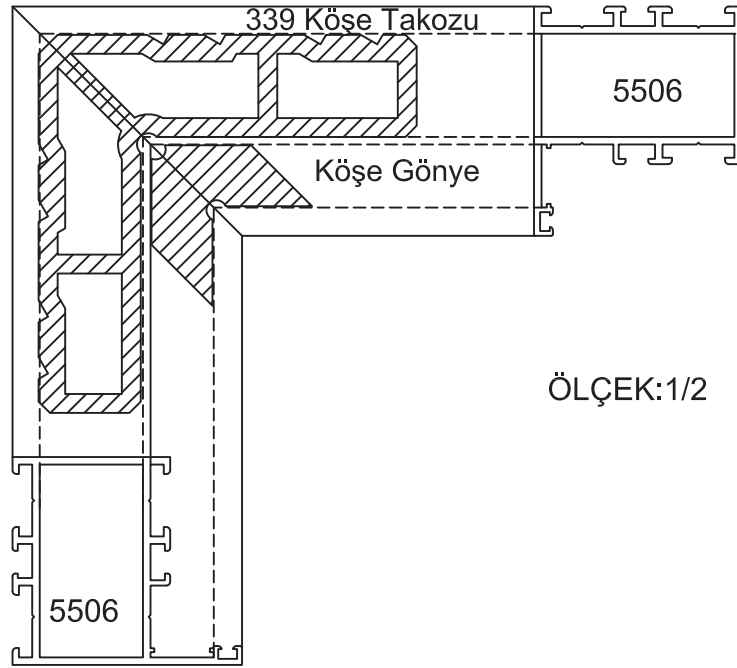

** Köşeler preslenmeden önce köşe takozu ve onbaşıya, epoksi tatbikatı uygulanır.

- Montaj Çizimleri
- Assembly Drawings

Yalıtımsız Kapı-Pencere Serisi

ORTA KAYIT BAĞLANTI DETAYI

